

National Exams May 2013

07-Mec-B9 ADVANCED ENGINEERING STRUCTURES

3 Hours Duration

NOTES:

1. If doubts exist as to the interpretation of any question, the candidate is urged to submit with the answer paper, a clear statement of any assumptions made.
2. Any non-communicating calculator is permitted. This is an open book exam.
3. Any FIVE (5) questions constitute a complete exam paper. If more than five questions are attempted, only the first five as they appear in the answer book will be marked.
4. All problems are of equal total value. Marks for individual questions are indicated within each problem.

1. An aircraft wing skin panel which can be modeled as a semi-infinite plate, has an edge crack of length 0.25 mm and is subjected to typical cyclic service loads. The component of those loads that act to propagate the crack can be simplified to constant amplitude stress loading of 200 N/mm^2 normal to the crack. If the panel is made from a metal alloy with fracture toughness of $3000 \text{ N/mm}^{3/2}$ and a crack growth rate of $35 \times 10^{-15} (\Delta K)^4$ mm/cycle, determine the maintenance interval required to detect the crack before it grows to half its critical length. (20 marks)
2. The steel compression strut BC of the frame ABC in the figure below is a steel tube with an outer diameter of 50 mm and a wall thickness of 4 mm. Determine the factor of safety against elastic buckling of BC if a distributed load is applied as shown below. Let $E = 200 \text{ GPa}$ and $\sigma_{\text{yielding}} = 320 \text{ MPa}$. (20 marks)

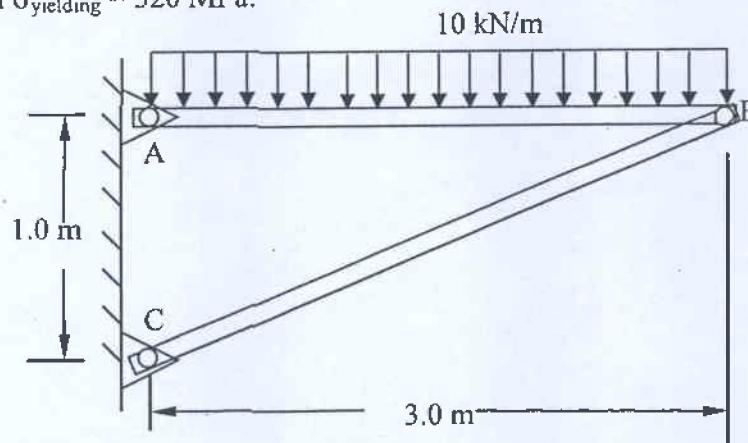

3. A thin-walled, cantilever beam supports two loads at its free end as shown below. Calculate the bending stress at the extremity of the lower flange (point A) at a section 2000 mm away from where the loads are applied. Assume the applied loads are acting at the shear center of the section. (20 marks)

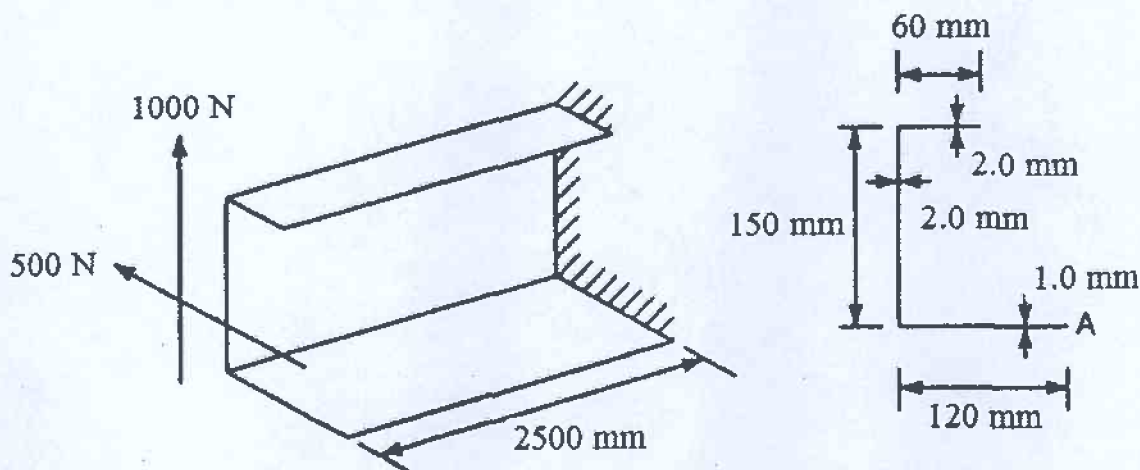

4. The horizontally symmetric, constant wall thickness (1 mm) thin walled idealized wing box shown below is subjected to a vertical shear force of 10,000 N acting upward. Assume wall 2-3 to be semicircular and take areas for booms 1 and 4 to be equal to 500 mm² and booms 2 and 3 to be equal to 400 mm². Finally, assume the thin walls to be only effective in shear.
- Determine the location of the shear center of the box (10 marks)
 - Determine the shear flow around the box if the upward shear force is acting 100 mm to the left of the shear center and the. (10 marks)

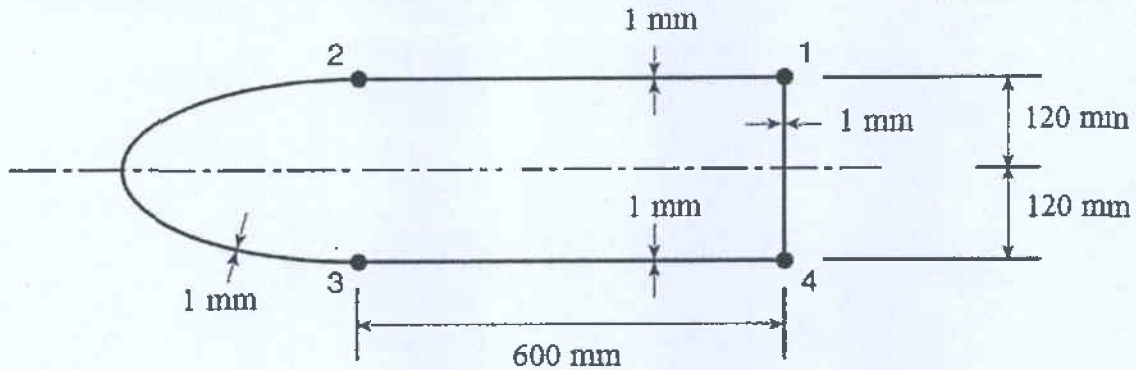

5. The following data points have been obtained from a series of mechanical strain cycling tests on an aircraft component:

Range of plastic strain $\Delta\epsilon$	Number of cycles to failure N
0.0400	200
0.0211	1000
0.0160	2000
0.0084	10000

- Show that these results can be represented by an equation of the type: $\Delta\epsilon = CN^\alpha$ Where C and α are material constants. (10 marks)
 - A component made from this material is subjected to a range of plastic strain of 0.015 for the first 500 cycles and then to a range of plastic strain of 0.01 for the rest of its service life. Calculate the total number of cycles before failure, assuming the material obeys Miner's cumulative damage law. (10 marks)
6. A cantilevered structural beam of solid square cross-section (w by w) is subjected at its free end to a compressive axial force of magnitude $P = 250$ kN and a torque $T = 13$ kN.m. This bar is to be designed in accordance with the maximum-shear-stress criterion of failure, with a safety factor of 3.
- What is the minimum allowable dimension w if $\sigma_{\text{yielding}} = 280$ MPa? (10 marks)
 - What would your answer be if the Von-Mises stress criterion is used? (10 marks)
7. The figure below shows a cantilevered, idealized wing box with shear loads applied at the free end as shown. The cross-sectional areas of the stringers are listed. Assuming the thin wall panels are only effective in resisting shear:

- a. find the shear flows in the panels at station $x = 2$ m, and
 b. determine the stringer loads at the same station.

(15 marks)
 (5 marks)

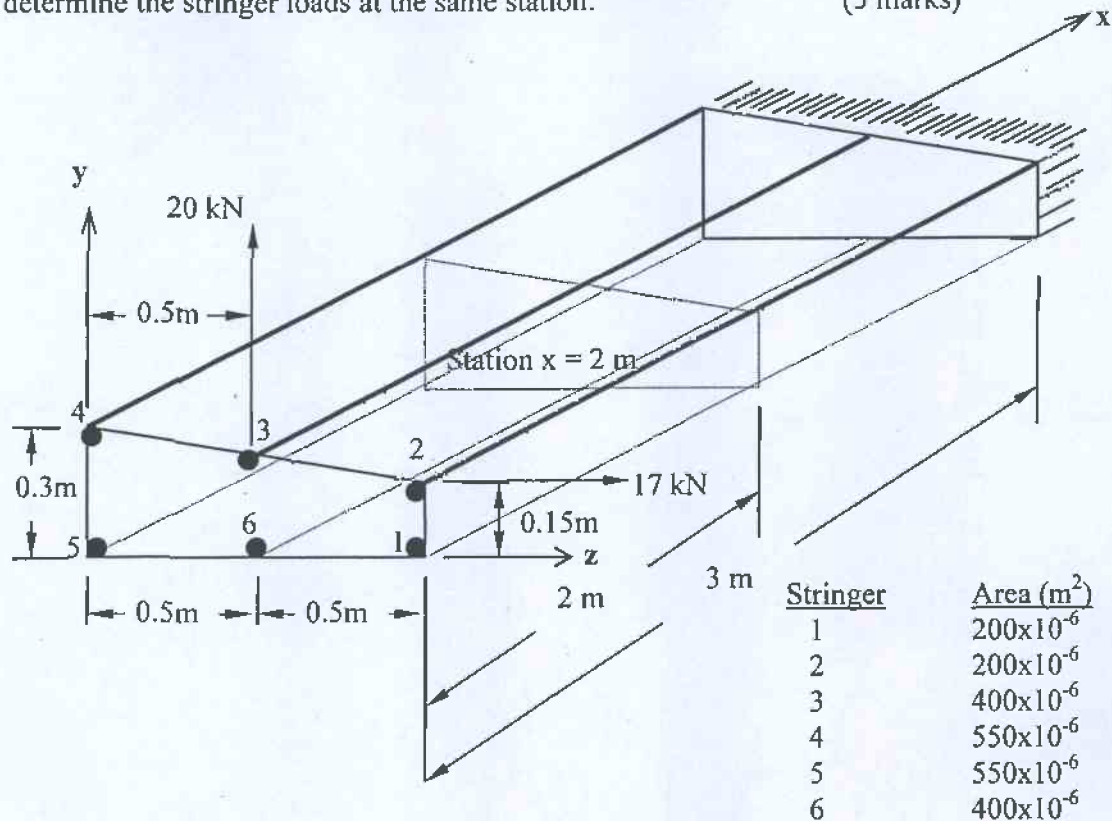

8. The closed thin wall beam with the cross section shown below (all dimensions are median distances in mm) and a wall thickness of 3 mm is subjected to the vertical force shown. If the webs are effective in bending as well as in shear, determine:
- a. The shear flow around the section (10 marks)
 b. The bending stresses at the 4 corners of a section on the beam located 300 mm behind the one shown (10 marks)

