

National Examinations – December 2016

98-Civ-A2, Elementary Structural Design

3 Hour Duration

NOTES

1. If doubt exists as to the interpretation of any question, the candidate is urged to submit with the answer paper a clear statement of any assumptions made.
2. This is a **"CLOSED BOOK"** examination. Handbooks and textbooks are permitted. **No notes or sheets are allowed.** Candidates may use one of two calculators, the Casio or Sharp approved models. You must indicate the type of calculator being used, i.e. write the name and model designation of your calculator on the first inside left-hand sheet of the exam work book.
3. Solutions must be to the following standards:

Steel:	CSA-S16 (latest edition)
Concrete:	CSA-A23.3 (latest edition)
Timber:	CSA-O86 (latest edition)
4. A total of **five** solutions is required. Only the first five as they appear in your answer book will be marked.

Do two questions from Part A.
Do two questions from Part B.
Do the one question in Part C.
5. All questions are of equal value.
6. **All loads shown are unfactored.**

Marking Scheme:

- A1: (12 + 8)
A2: (8 + 12)
A3: (8 + 12)
B1: (12 + 8)
B2: (10 + 8 + 2)
B3: (12 + 8)
C1: (8 + 6 + 6)

Part A (Do two of three questions)

- A1. The rigidly connected steel column, W610 x 241, of G40.21 300W is made up of two equal lengths, AB and BC, as shown in Figure A1. Design a welded rigid connection at B for the given loads.
- A2. Figure A2 shows a built-up steel cross-section. It is fabricated from 20-mm G40.21-M350W steel plates. Determine the section moments of resistance about the two centroidal axes x-x and y-y.
- A3. The cross-section in Figure A2 is used as a column in a one-storey industrial building. The base of the column is fixed to the foundation and its top can be assumed to be translation free. The column is 6 m high and subjected to a vertical load P_f , applied at A, a distance of 0.5 m from the centre O, and along axis OA. Calculate the maximum factored load P_f the column can carry.

Part B (Do two of three questions)

- B1. A reinforced concrete beam with two overhangs, is loaded as shown in Figure B1. Determine the dimensions of its rectangular cross-section and the steel reinforcements to satisfy moment and shear. Take into account the self-weight of the beam. (Use $f_c' = 35$ MPa and $f_y = 400$ MPa.)
- B2. Figure B2 shows the profile of a determinate reinforced concrete frame, ABC. Design a rectangular cross-section and the reinforcing for flexure and shear of beam BC and the column AB. Show the layout of the reinforcement. (Use $f_c' = 35$ MPa and $f_y = 400$ MPa.)
- B3. A reinforced concrete triple T-section has dimensions and reinforcement as shown in Figure B3. Calculate its moment of resistance, M_r and the shear resistance, V_r . (Use $f_c' = 35$ MPa and $f_y = 400$ MPa.)

Part C (Do question C1)

- C1. The determinate frame ABC in Figure B2 is to be designed in timber for a storage building. Design a Douglas-fir glulam rectangular section for the frame, loaded as shown, to satisfy the following conditions: (a) permanent load duration; (b) dry service conditions; and (c) treated.

[Assume any other data that may be required].

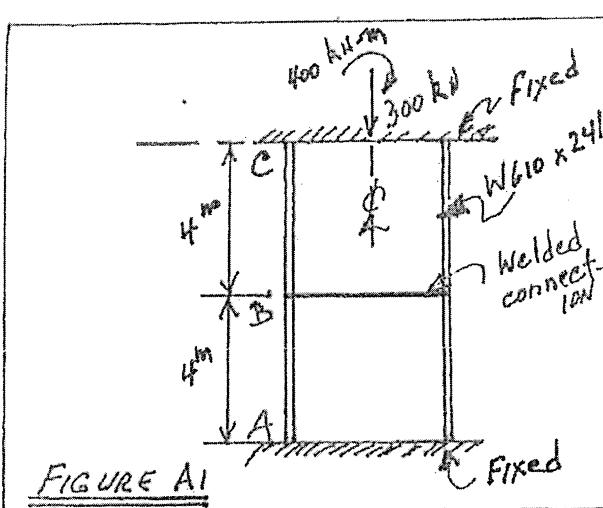

FIGURE A1

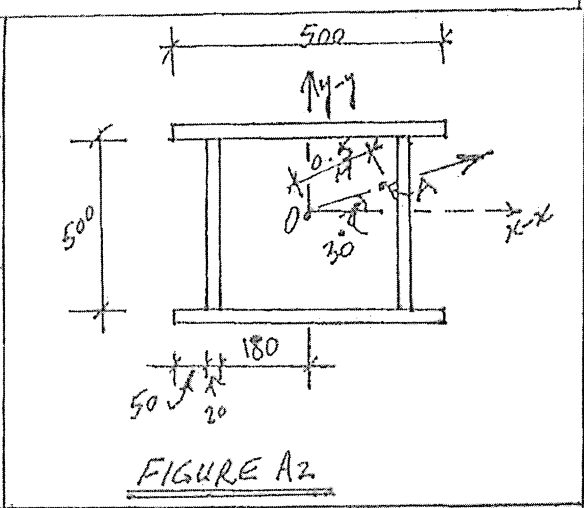

FIGURE A2

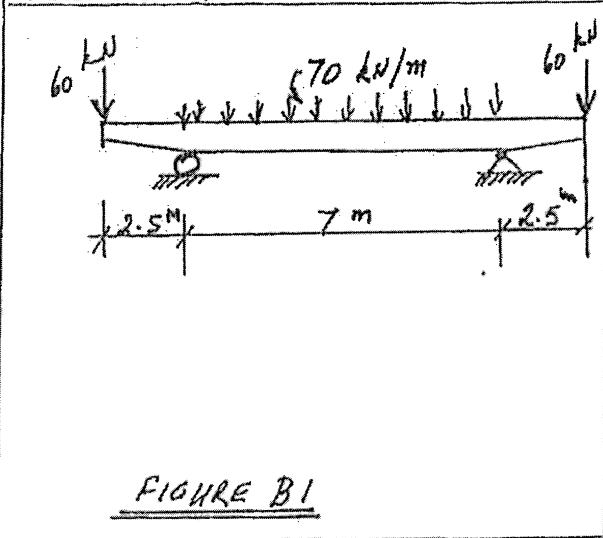

FIGURE B1

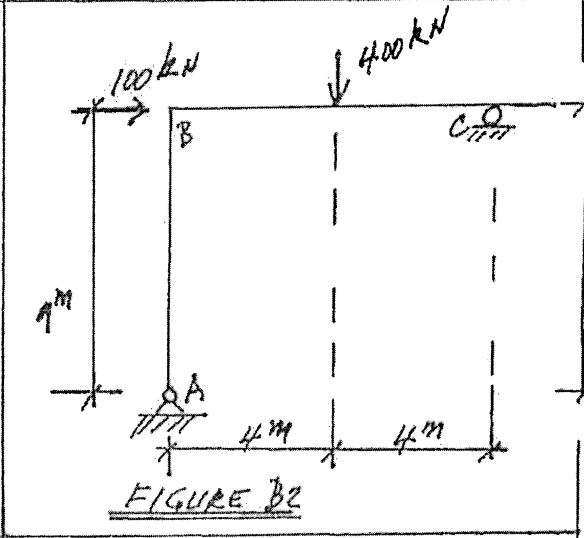

FIGURE B2

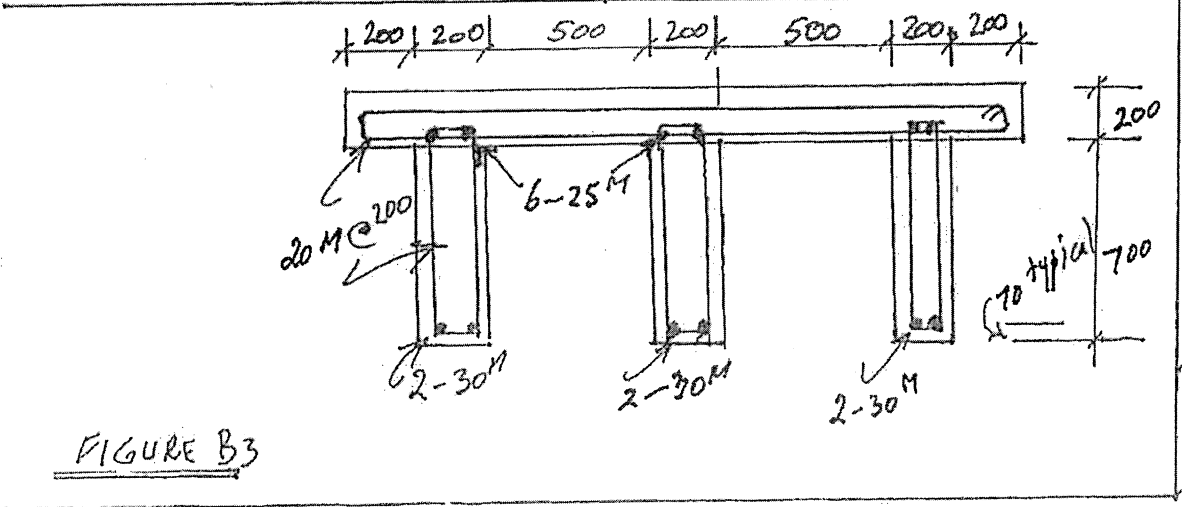

FIGURE B3