

## National Exams May 2016

### 98-Phys-A1, Classical Mechanics

3 hours duration

#### NOTES:

1. If doubt exists as to the interpretation of any question, the candidate is urged to submit with the answer paper, a clear statement of any assumptions made.
2. This is a CLOSED BOOK EXAM.  
A Casio or Sharp approved calculator is permitted.
3. FIVE (5) questions constitute a complete exam paper.  
The first five questions as they appear in the answer book will be marked.
4. Each question is of equal value.
5. Most questions require an answer in essay format. Clarity and organization of the answer are important.

## 2016, 98-A1-Phys Classical Mechanics

1. A  $2\text{-kg}$  sphere of  $1\text{-m}$  diameter was initially at rest on top of a  $5\text{-kg}$  wedge-shape surface with a  $30\text{-degree}$  angle; see Figure. The surface is free to roll on a horizontal ground. Assume the motion maintains its plane-of-motion in the  $X\text{-}Y$  plane shown in the Figure. No friction should be considered and neglect the mass of the wheels of the surface. Answer the following questions. (a) Is the constraint of motion holonomic or non-holonomic as it rolls down the slope? Provide your reasons. (b) How many degrees-of-freedom are needed to describe the motion of the sphere? (c) Use the Lagrange's equations to find the force of the constraint. Note, the moment of inertia of a uniform sphere rotating about its mass center is  $\frac{2mr^2}{5}$  where  $m$  is the mass and  $r$  is the radius of the sphere.

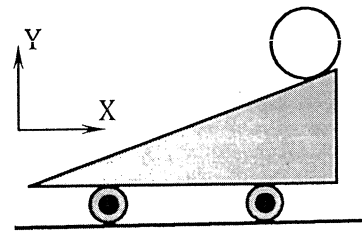

2. Consider the motion of a particle of mass  $m$  constrained on a cylindrical surface of radius  $R$ ; see Figure. The particle is subjected to a force that is directed towards the origin and proportional to its radial distance:  $\vec{F} = -k\vec{r}$ . Answer the following questions. (a) Write down the Hamiltonian of the particle's motion and derive the equations of motion based on the Hamiltonian. (b) Consider the frame  $xyZ$  by rotating a (fixed)  $\phi$  angle clockwise from the  $Z$  axis of the  $XYZ$  frame. How would the equations of motion be different when expressed in the  $xyZ$  frame? (c) Write down any invariant property of the dynamics described in the  $XYZ$  and  $xyZ$  frames.

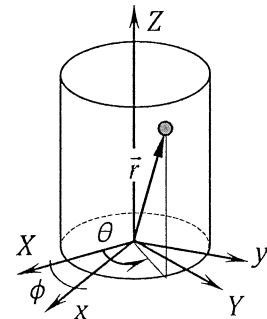

3. The mechanical system shown in the Figure consists of a crank  $AB$ , a slider  $B$  and a slotted rod  $CD$ . At the instant shown, the crank has an angular velocity and acceleration,  $\vec{\omega}_{AB} = 3\vec{k}$   $rad/s$ ,  $\vec{\alpha}_{AB} = -1\vec{k}$   $rad/s^2$ , respectively. Determine the velocity and acceleration of the slider  $B$  relative to the slotted rod at this instant.

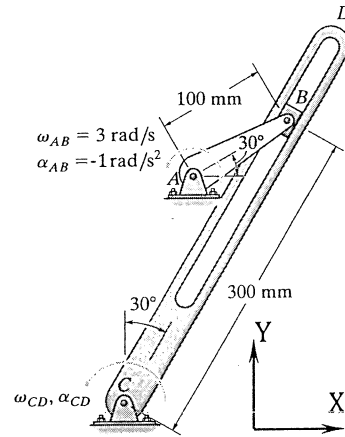

4. A 1-kg cart, a 0.1-kg ball, and an elastic cord *connecting the ball and the cart*, are placed in a weightless environment; see Figure. The cart has a shape of a symmetric trapezoid with its left and right edges at a 60-deg angle from the vertical. It is also attached with four rollers (two on top and two on bottom) so that it can move freely horizontally. At  $t = 0$ , the system is in static equilibrium with the elastic cord fully stretched to exert a force of  $\vec{F}_s = -1\vec{i}$  N force on the cart. The ball is then released from rest in its  $t = 0$  position and hits the cart at  $t = 2$  seconds. Note that the attachment of the elastic cord is at exactly the same level as the center of mass (C.M.) of the cart. Answer the following questions. (a) Will the cart move right after the release of the ball ( $t = 0^+$ )? Provide your reason(s). (b) What are the impulsive forces at the instant the ball hits the cart? (c) Assume the ball sticks to the cart surface, what is the speed of the cart right after the ball hits the cart? Neglect the mass of the string.

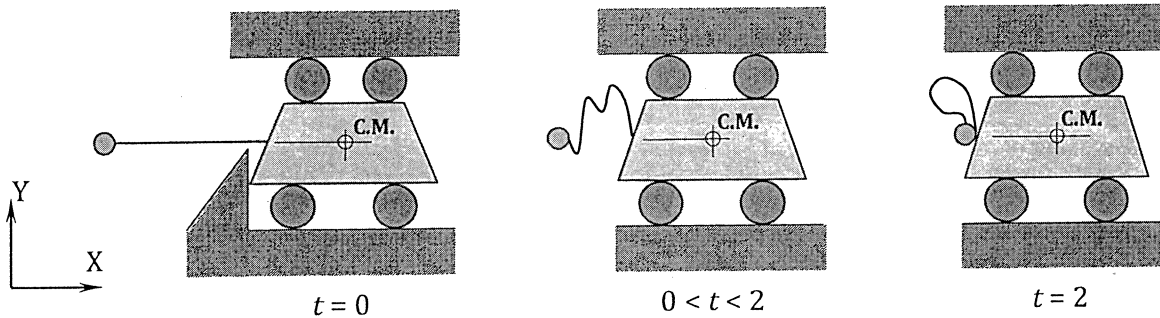

5. Assume the angular velocity and the inertia tensor of a rigid body,  $\vec{\omega} = \omega_x \vec{i} + \omega_y \vec{j} + \omega_z \vec{k}$ , and  $I$ , respectively. Let  $I_{xx}, I_{yy}, I_{zz}$  be the principal axes of  $I$ . (a) Assume the rigid body satisfies the condition  $I_{xx} = I_{yy} = I_{zz}$ , and an impulsive moment  $\vec{M}(t) = \vec{M}_0 \delta(t)$  is applied to the body where  $\vec{M}_0 = a\vec{i} + b\vec{j} + c\vec{k}$ , is a fixed vector with  $a, b, c > 0$ , and  $\delta(t)$  is the Dirac delta function. Discuss how the rotation will progress for  $t > 0$  and provide the basis of your reasoning. (b) Assume the body satisfies the condition  $I_{xx} > I_{yy} > I_{zz}$  and  $\vec{M}(t) = \vec{M}_0 \delta(t) = (a\vec{i} + 0\vec{j} + c\vec{k})\delta(t)$  with  $a, c > 0$ . Discuss how the rotation will progress for  $t > 0$  and provide the basis of your reasoning.

6. At  $t = 0$ , the cable attached to the rigid rod at point  $B$  snaps; see Figure. The rod has a mass of  $1 \text{ kg}$ . Assume the spring immediately detaches from the rod for  $t > 0$ . Determine the angular velocity and the acceleration at the center of mass of the rod  $AB$  after one second.

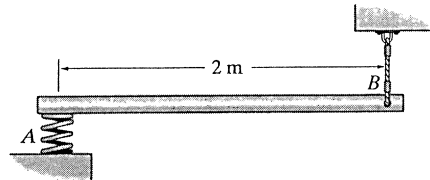



Professional Engineers  
Ontario

### Technical Exam For Approval

DATE: \_\_\_\_\_

EXAMINATION: **98-Phys-AI, Classical Mechanics**

REVIEWER'S NAME & ADDRESS: \_\_\_\_\_ Dr. D.C.D. Oguamanam (PEO member)\_\_\_\_  
(indicate P.Eng. if a member)

\_\_\_\_\_  
\_\_\_\_\_

Telephone Number: \_\_\_\_\_ 4169795000 x 7490 \_\_\_\_\_

Date of Birth: \_\_\_\_\_ SIN: \_\_\_\_\_  
(If Date of Birth and SIN never submitted to our office please do so since payroll requires info for our record)

#### REVIEWER'S DECISION:

Are the questions set a fair representation of the current syllabus? \_\_\_\_\_  
If no selected, provide your comments below.

Are any questions set outside the current syllabus? \_\_\_\_\_  
If yes selected, indicate the questions.

Paper requires minor correction(s) e.g. spelling. \_\_\_\_\_

Paper requires review with examiner; see Comments. \_\_\_\_\_

Level of difficulty of exam in your opinion is: Fair \_\_\_\_\_ Difficult \_\_\_\_\_  
*Note: if difficult selected; indicate which question(s)*

Paper is acceptable without changes \_\_\_\_\_

Paper is unacceptable, and should be redone; see Comments \_\_\_\_\_

#### COMMENTS:

\_\_\_\_\_  
\_\_\_\_\_  
\_\_\_\_\_

\_\_\_\_\_  
Reviewer's Signature

## **98-Phys-A1, Classical Mechanics**

### **Synopsis of Examination Paper**

1. This is a question on the basic knowledge about constraints, Lagrange's equations and Lagrange multipliers. The Candidates also require the basic notion of impulse momentum principle to solve the problem.
2. This is a problem on the basic knowledge about Hamiltonian mechanics applied to particle central force motion, and the derivation of equations of motion given the Hamiltonian. The Candidates also require intermediate level knowledge to understand the concept of invariance in classical mechanics.
3. This is a problem related to rigid body kinematics using rotating frame.
4. This is a problem related to impulse-momentum principle and its application to impact problem.
5. This is a problem related to rigid body rotation and Euler equations of motion. The Candidates are required to demonstrate knowledge in the stability analysis of rigid body rotation.
6. This is a problem about the basic understanding of rigid body kinetics using Newton's law.