

NATIONAL EXAMINATIONS MAY 2016

98-Phys-B6 Applied Thermodynamics and Heat Transfer

3 Hours Duration

Notes :

1. If doubt exists concerning the interpretation of any question, the candidate is urged to make assumptions and clearly explain what has been assumed along with the answer to the question.
2. The examination is open book. As a consequence, candidates are permitted to make use of any textbooks, references or notes.
3. Any non-communicating calculator is permitted. However, candidates must indicate the type of calculator(s) that they have used by writing the name and model designation of the calculator(s) on the inside of the cover of the first examination book.
4. It is expected that each candidate will have copies of both a thermodynamics text and a heat transfer text in order to make use of the information presented in the tables and graphs contained.
5. The answers to five questions, either three questions from Part A and two questions from Part B or two questions from Part A and three questions from Part B, comprise a complete examination.
6. Candidates must indicate the answers that they wish to have graded on the cover of the first examination book. Otherwise the answers will be graded in the order in which they appear in the examination book(s) up to a maximum of three answers per section.
7. The answer to any question carries the same value in the grading.

PART A - THERMODYNAMICS

1.(a) Gas is contained in two cylinders A and B connected by a piston having two different diameters as depicted in the illustration. The mass of the piston is 10 kg and the gas pressure inside cylinder A is 200 kPa. Determine the gas pressure inside cylinder B.

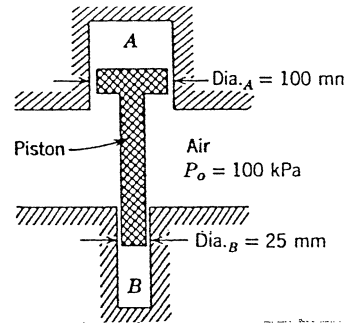

(b) Saturated water vapour at 200°C is contained in a cylinder fitted with a piston. The initial volume of the steam is 0.01 m^3 . The steam expands in a quasiequilibrium isothermal process until the final pressure is 200 kPa and in so doing does work against the piston. How much work is done during the process? How much error would be made by assuming the steam to behave as an ideal gas?

2. A combined reheat / regeneration cycle utilizes steam as the working fluid. The steam enters the high pressure turbine at 3.5 MPa and 350°C from which some is extracted at 0.8 MPa for the purposes of feedwater heating. The remainder of the steam is reheated to 350°C after which it enters the low pressure turbine from which some is extracted at 0.2 MPa for feedwater heating. The condenser pressure is 10 kPa and both feedwater heaters are open. Depict the cycle on a T-s diagram and determine the thermal efficiency and the net work output per kilogram of flowing steam.

3. Air enters the compressor of a Brayton cycle at 20°C and 100 kPa and leaves at a pressure of 475 kPa. The maximum temperature of the cycle is limited to 870°C by metallurgical considerations. Assuming a compressor efficiency of 82%, a turbine efficiency of 85% and a pressure drop of 13.7 kPa between the compressor and the turbine, determine (a) the pressure and temperature at each point in the cycle (b) the net work of the cycle (c) the thermal efficiency of the cycle and the percentage of the turbine work required to drive the compressor. Sketch the cycle on a temperature entropy diagram.

4. The following test data were obtained with a Freon-12 vapour compression refrigeration system operating at steady state.

Condenser pressure	700 kPa	
Evaporator pressure	150 kPa	
Temperature at compressor inlet		0°C
compressor outlet		70°C
condenser inlet		60°C
condenser outlet		15°C
expansion valve inlet		20°C
evaporator outlet		-10°C

The heat transferred from the refrigerant during compression is 3.35 kJ/kg. Depict the refrigeration cycle on a T-s diagram and determine the coefficient of performance of the cycle and the thermal efficiency of the compression process.

Continued on Page 3

PART B - HEAT TRANSFER

5. Steam flows through a copper tube having an outside diameter $D = 2.54$ cm and a wall thickness $\delta = 0.54$ cm. The inside surface temperature $T_i = 100^\circ\text{C}$ and the temperature of the room in which the tube is located $T_\infty = 27^\circ\text{C}$. Determine the thickness of insulation having thermal conductivity $k = 0.0875$ W/m $^\circ\text{C}$ required to reduce the heat loss to the surrounding air by 95% when the tube is cooled by forced convection heat transfer where $\bar{h} = 55$ W/m 2 $^\circ\text{C}$. What would the outside surface temperature T_o be under these conditions ?

6. Oil flowing at $\dot{m} = 0.25$ kg/s enters a thin-walled tube 50 mm diameter by 6 m long at $T_{m,i} = 23^\circ\text{C}$ where it is heated by a hot gas at $T_\infty = 300^\circ\text{C}$ moving in crossflow over the tube at $V = 10$ m/s. The gas may be assumed to have the same thermophysical properties as those of air. In order to prevent the oil overheating and decomposing, the temperature of the wall must not exceed $T_t = 100^\circ\text{C}$ anywhere along the tube. Will there be any problem associated with heating the oil under these conditions ?

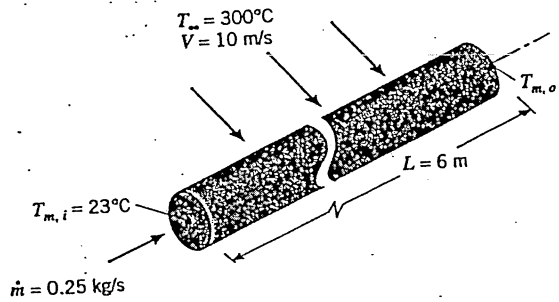

7. The illustration depicts a power transistor that dissipates 0.18 W when the temperature of the enclosure in which it is located is 35°C and the temperature of the air surrounding it is 25°C . The emissivity of its surface is 0.1. Disregarding any heat transfer from the base, determine the surface temperature of the power transistor.

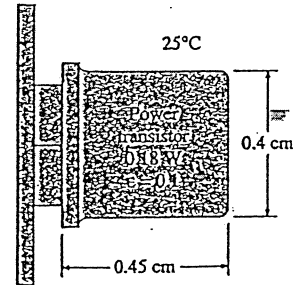

8. A crossflow heat exchanger is comprised of 40 thin-walled tubes 1 cm in diameter located in a duct 1 m x 1 m in cross section. Cold water ($C_p = 4180$ J/kg $^\circ\text{C}$) enters the tubes at 18°C with an average velocity of 3 m/s while hot air ($C_p = 1010$ J/kg $^\circ\text{C}$) enters the channel at 130°C and 105 kPa with an average velocity of 12 m/s. If the overall heat transfer coefficient is 80 W/m 2 $^\circ\text{C}$, determine the temperatures at which the water and the air leave the heat exchanger and the rate of heat transfer.

The End

Thermodynamic Properties of Freon-12 (Dichlorodifluoromethane)^a

Saturated Freon-12

Temp. °C	Abs. Press. MPa P	Specific Volume m ³ /kg			Enthalpy kJ/kg			Entropy kJ/kg K		
		Sat. Liquid <i>v_f</i>	Evap. <i>v_{fg}</i>	Sat. Vapor <i>v_g</i>	Sat. Liquid <i>h_f</i>	Evap. <i>h_{fg}</i>	Sat. Vapor <i>h_g</i>	Sat. Liquid <i>s_f</i>	Evap. <i>s_{fg}</i>	Sat. Vapor <i>s_g</i>
-90	0.0028	0.000 608	4.414 937	4.415 545	-43.243	189.618	146.375	-0.2084	1.0352	0.8268
-85	0.0042	0.000 612	3.036 704	3.037 316	-38.968	187.608	148.640	-0.1854	0.9970	0.8116
-80	0.0062	0.000 617	2.137 728	2.138 345	-34.688	185.612	150.924	-0.1630	0.9609	0.7979
-75	0.0088	0.000 622	1.537 030	1.537 651	-30.401	183.625	153.224	-0.1411	0.9266	0.7855
-70	0.0123	0.000 627	1.126 654	1.127 280	-26.103	181.640	155.536	-0.1197	0.8940	0.7744
-65	0.0168	0.000 632	0.840 534	0.841 166	-21.793	179.651	157.857	-0.0987	0.8630	0.7643
-60	0.0226	0.000 637	0.637 274	0.637 910	-17.469	177.653	160.184	-0.0782	0.8334	0.7552
-55	0.0300	0.000 642	0.490 358	0.491 000	-13.129	175.641	162.512	-0.0581	0.8051	0.7470
-50	0.0391	0.000 648	0.382 457	0.383 105	-8.772	173.611	164.840	-0.0384	0.7779	0.7396
-45	0.0504	0.000 654	0.302 029	0.302 682	-4.396	171.558	167.163	-0.0190	0.7519	0.7329
-40	0.0642	0.000 659	0.241 251	0.241 910	-0.000	169.479	169.479	-0.0000	0.7269	0.7269
-35	0.0807	0.000 666	0.194 732	0.195 398	4.416	167.368	171.784	0.0187	0.7027	0.7214
-30	0.1004	0.000 672	0.158 703	0.159 375	8.854	165.222	174.076	0.0371	0.6795	0.7165
-25	0.1237	0.000 679	0.130 487	0.131 166	13.315	163.037	176.352	0.0552	0.6570	0.7121
-20	0.1509	0.000 685	0.108 162	0.108 847	17.800	160.810	178.610	0.0730	0.6352	0.7082
-15	0.1826	0.000 693	0.090 326	0.091 018	22.312	158.534	180.846	0.0906	0.6141	0.7046
-10	0.2191	0.000 700	0.075 946	0.076 646	26.851	156.207	183.058	0.1079	0.5936	0.7014
-5	0.2610	0.000 708	0.064 255	0.064 963	31.420	153.823	185.243	0.1250	0.5736	0.6986
0	0.3086	0.000 716	0.054 673	0.055 389	36.022	151.376	187.397	0.1418	0.5542	0.6960
5	0.3626	0.000 724	0.046 761	0.047 485	40.659	148.859	189.518	0.1585	0.5351	0.6937
10	0.4233	0.000 733	0.040 180	0.040 914	45.337	146.265	191.602	0.1750	0.5165	0.6916
15	0.4914	0.000 743	0.034 671	0.035 413	50.058	143.586	193.644	0.1914	0.4983	0.6897
20	0.5673	0.000 752	0.030 028	0.030 780	54.828	140.812	195.641	0.2076	0.4803	0.6879
25	0.6516	0.000 763	0.026 091	0.026 854	59.653	137.933	197.586	0.2237	0.4626	0.6863
30	0.7449	0.000 774	0.022 734	0.023 508	64.539	134.936	199.475	0.2397	0.4451	0.6848
35	0.8477	0.000 786	0.019 855	0.020 641	69.494	131.805	201.299	0.2557	0.4277	0.6834
40	0.9607	0.000 798	0.017 373	0.018 171	74.527	128.525	203.051	0.2716	0.4104	0.6820
45	1.0843	0.000 811	0.015 220	0.016 032	79.647	125.074	204.722	0.2875	0.3931	0.6806
50	1.2193	0.000 826	0.013 344	0.014 170	84.868	121.430	206.298	0.3034	0.3758	0.6792
55	1.3663	0.000 841	0.011 701	0.012 542	90.201	117.565	207.766	0.3194	0.3582	0.6777
60	1.5259	0.000 858	0.010 253	0.011 111	95.665	113.443	209.109	0.3355	0.3405	0.6760
65	1.6988	0.000 877	0.008 971	0.009 847	101.279	109.024	210.303	0.3518	0.3224	0.6742
70	1.8858	0.000 897	0.007 828	0.008 725	107.067	104.255	211.321	0.3683	0.3038	0.6721
75	2.0874	0.000 920	0.006 802	0.007 723	113.058	99.068	212.126	0.3851	0.2845	0.6697
80	2.3046	0.000 946	0.005 875	0.006 821	119.291	93.373	212.665	0.4023	0.2644	0.6667
85	2.5380	0.000 976	0.005 029	0.006 005	125.818	87.047	212.865	0.4201	0.2430	0.6631
90	2.7885	0.001 012	0.004 246	0.005 258	132.708	79.907	212.614	0.4385	0.2200	0.6585
95	3.0569	0.001 056	0.003 508	0.004 563	140.068	71.658	211.726	0.4579	0.1946	0.6526
100	3.3440	0.001 113	0.002 790	0.003 903	148.076	61.768	209.843	0.4788	0.1655	0.6444
105	3.6509	0.001 197	0.002 045	0.003 242	157.085	49.014	206.099	0.5023	0.1296	0.6319
110	3.9784	0.001 364	0.001 098	0.002 462	168.059	28.425	196.484	0.5322	0.0742	0.6064
112	4.1155	0.001 792	0.000 005	0.001 797	174.920	0.151	175.071	0.5651	0.0004	0.5655

^aCopyright 1955 and 1956, E. I. du Pont de Nemours & Company, Inc. Reprinted by permission. Adapted from English units.

Superheated Freon-12

Temp. °C	v m ³ /kg	h kJ/kg	s kJ/kg K	v m ³ /kg	h kJ/kg	s kJ/kg K	v m ³ /kg	h kJ/kg	s kJ/kg K
0.05 MPa									
-20.0	0.341 857	181.042	0.7912	0.167 701	179.861	0.7401	0.114 716	184.619	0.7318
-10.0	0.356 227	186.757	0.8133	0.175 222	185.707	0.7628	0.119 866	190.660	0.7543
0.0	0.370 508	192.567	0.8350	0.182 647	191.628	0.7849	0.124 932	196.762	0.7763
10.0	0.384 716	198.471	0.8562	0.189 994	197.628	0.8064	0.129 930	202.927	0.7977
20.0	0.398 863	204.469	0.8770	0.197 277	203.707	0.8275	0.134 873	209.160	0.8186
30.0	0.412 959	210.557	0.8974	0.204 506	209.866	0.8482	0.139 768	215.463	0.8390
40.0	0.427 012	216.733	0.9175	0.211 691	216.104	0.8684	0.144 625	221.835	0.8591
50.0	0.441 030	222.997	0.9372	0.218 839	222.421	0.8883	0.149 450	228.277	0.8787
60.0	0.455 017	229.344	0.9565	0.225 955	228.815	0.9078	0.154 247	234.789	0.8980
70.0	0.468 978	235.774	0.9755	0.233 044	235.285	0.9269	0.159 020	241.371	0.9169
80.0	0.482 917	242.282	0.9942	0.240 111	241.829	0.9457	0.163 774	248.020	0.9354
90.0	0.496 838	248.868	1.0126	0.247 159	248.446	0.9642			
0.10 MPa									
0.15 MPa									
0.20 MPa									
0.0	0.088 608	189.669	0.7320	0.069 752	188.644	0.7139	0.057 150	187.583	0.6984
10.0	0.092 550	195.878	0.7543	0.073 024	194.969	0.7366	0.059 984	194.034	0.7216
20.0	0.096 418	202.135	0.7760	0.076 218	201.322	0.7587	0.062 734	200.490	0.7440
30.0	0.100 228	208.446	0.7972	0.079 350	207.715	0.7801	0.065 418	206.969	0.7658
40.0	0.103 989	214.814	0.8178	0.082 431	214.153	0.8010	0.068 049	213.480	0.7869
50.0	0.107 710	221.243	0.8381	0.085 470	220.642	0.8214	0.070 635	220.030	0.8075
60.0	0.111 397	227.735	0.8578	0.088 474	227.185	0.8413	0.073 185	226.627	0.8276
70.0	0.115 055	234.291	0.8772	0.091 449	233.785	0.8608	0.075 705	233.273	0.8473
80.0	0.118 690	240.910	0.8962	0.094 398	240.443	0.8800	0.078 200	239.971	0.8665
90.0	0.122 304	247.593	0.9149	0.097 327	247.160	0.8987	0.080 673	246.723	0.8853
100.0	0.125 901	254.339	0.9332	0.100 238	253.936	0.9171	0.083 127	253.530	0.9038
110.0	0.129 483	261.147	0.9512	0.103 134	260.770	0.9352	0.085 566	260.391	0.9220
0.25 MPa									
0.30 MPa									
0.40 MPa									
20.0	0.045 836	198.762	0.7199	0.035 646	196.935	0.6999	0.030 422	202.116	0.7063
30.0	0.047 971	205.428	0.7423	0.037 464	203.814	0.7230	0.031 966	209.154	0.7291
40.0	0.050 046	212.095	0.7639	0.039 214	210.656	0.7452	0.033 450	216.141	0.7511
50.0	0.052 072	218.779	0.7849	0.040 911	217.484	0.7667	0.034 887	223.104	0.7723
60.0	0.054 059	225.488	0.8054	0.042 565	224.315	0.7875	0.036 285	230.062	0.7929
70.0	0.056 014	232.230	0.8253	0.044 184	231.161	0.8077	0.037 653	237.027	0.8129
80.0	0.057 941	239.012	0.8448	0.045 774	238.031	0.8275	0.038 995	244.009	0.8324
90.0	0.059 846	245.837	0.8638	0.047 340	244.932	0.8467	0.040 316	251.016	0.8514
100.0	0.061 731	252.707	0.8825	0.048 886	251.869	0.8656	0.041 619	258.053	0.8700
110.0	0.063 600	259.624	0.9008	0.050 415	258.845	0.8840	0.042 907	265.124	0.8882
120.0	0.065 455	266.590	0.9187	0.051 929	265.862	0.9021	0.044 181	272.231	0.9061
130.0	0.067 298	273.605	0.9364	0.053 430	272.923	0.9198			
0.50 MPa									
0.60 MPa									
0.70 MPa									
40.0	0.026 761	207.580	0.7148	0.022 830	205.924	0.7016	0.019 744	204.170	0.6982
50.0	0.028 100	214.745	0.7373	0.024 068	213.290	0.7248	0.020 912	211.765	0.7131
60.0	0.029 387	221.854	0.7590	0.025 247	220.558	0.7469	0.022 012	219.212	0.7358
70.0	0.030 632	228.931	0.7799	0.026 380	227.766	0.7682	0.023 062	226.564	0.7575
80.0	0.031 843	235.997	0.8002	0.027 477	234.941	0.7888	0.024 072	233.856	0.7785
90.0	0.033 027	243.066	0.8199	0.028 545	242.101	0.8088	0.025 051	241.113	0.7987
100.0	0.034 189	250.146	0.8392	0.029 588	249.260	0.8283	0.026 005	248.355	0.8184
110.0	0.035 332	257.247	0.8579	0.030 612	256.428	0.8472	0.026 937	255.593	0.8376
120.0	0.036 458	264.374	0.8763	0.031 619	263.613	0.8657	0.027 851	262.839	0.8562
130.0	0.037 572	271.531	0.8943	0.032 612	270.820	0.8838	0.028 751	270.100	0.8745
140.0	0.038 673	278.720	0.9119	0.033 592	278.055	0.9016	0.029 639	277.381	0.8923
150.0	0.039 764	285.946	0.9292	0.034 563	285.320	0.9189	0.030 515	284.687	0.9098
0.80 MPa									
0.90 MPa									
1.00 MPa									
50.0	0.018 366	210.162	0.7021	0.014 483	206.661	0.6812	0.012 579	211.457	0.6876
60.0	0.019 410	217.810	0.7254	0.015 463	214.805	0.7060	0.013 448	219.822	0.7123
70.0	0.020 397	225.319	0.7476	0.016 368	222.687	0.7293	0.014 247	227.891	0.7355
80.0	0.021 341	232.739	0.7689	0.017 221	230.398	0.7514	0.014 997	235.766	0.7575
90.0	0.022 251	240.101	0.7895	0.018 032	237.995	0.7727	0.015 710	243.512	0.7785
100.0	0.023 133	247.430	0.8094	0.018 812	245.518	0.7931	0.016 393	251.170	0.7988
110.0	0.023 993	254.743	0.8287	0.019 567	252.993	0.8129	0.017 053	258.770	0.8183
120.0	0.024 835	262.053	0.8475	0.020 301	260.441	0.8320	0.017 695	266.334	0.8373
130.0	0.025 661	269.369	0.8659	0.021 018	267.875	0.8507	0.018 321	273.877	0.8558
140.0	0.026 474	276.699	0.8839	0.021 721	275.307	0.8689	0.018 934	281.411	0.8738
150.0	0.027 275	284.047	0.9015	0.022 412	282.745	0.8867	0.019 535	288.946	0.8914
160.0	0.028 068	291.419	0.9187	0.023 093	290.195	0.9041			
1.20 MPa									
1.40 MPa									
1.60 MPa									
70.0	0.011 208	216.650	0.6959	0.009 406	213.049	0.6794	0.008 704	218.859	0.6909
80.0	0.011 984	225.177	0.7204	0.010 187	222.198	0.7057	0.009 406	228.056	0.7166
90.0	0.012 698	233.390	0.7433	0.010 884	230.835	0.7298	0.010 035	236.760	0.7402
100.0	0.013 366	241.397	0.7651	0.011 526	239.155	0.7524	0.010 615	245.154	0.7624
110.0	0.014 000	249.264	0.7859	0.012 126	247.264	0.7739	0.011 159	253.341	0.7835
120.0	0.014 608	257.035	0.8059	0.012 697	255.228	0.7944	0.011 676	261.384	0.8037
130.0	0.015 195	264.742	0.8253	0.013 244	263.094	0.8141	0.012 172	269.327	0.8232
140.0	0.015 765	272.406	0.8440	0.013 772	270.891	0.8332	0.012 651	277.201	0.8420
150.0	0.016 320	280.044	0.8623	0.014 284	278.642	0.8518			
1.80 MPa									
2.00 MPa									