

**National Exams May 2015**  
**Mec-A2, Kinematics and Dynamics of Machines**  
3 Hours in Duration

**Notes:**

1. If doubt exists as to the interpretation of any question, the candidate is urged to submit with the answer paper, a clear statement of any assumptions made.
2. This is an OPEN BOOK exam. Any Sharp or Casio approved calculators are permitted.
3. Answer FIVE questions from the six questions provided.
4. Marks for each question are 20.

Front Page

1. The crank (input link) of a six-bar mechanism shown below rotates CW at a speed of 100 rad/s. Link 6 is the output link. Determine for the shown position (i) all instant centers, (ii) the mechanical advantage, and (iii) the angular velocity of the output link.

Scale 1: 5

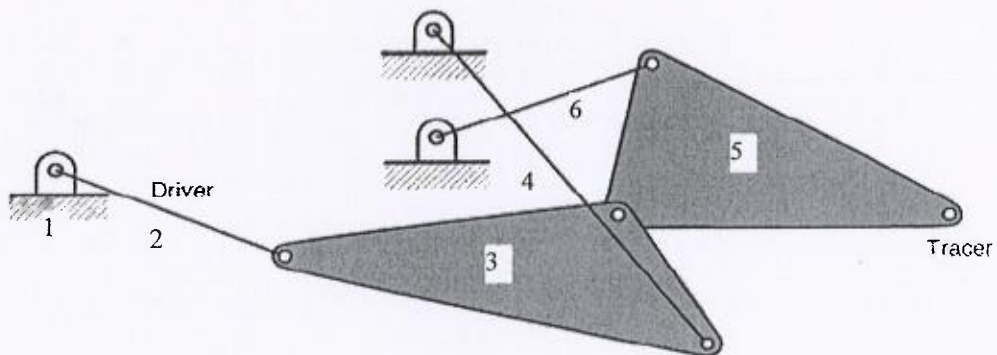

2. A radial cam, rotating at a constant angular velocity of 900 rpm, is used to produce the following follower motion:

- rise by 12.7 mm from 0 mm position during  $[0, 150^\circ]$ ,
- dwell at 12.7 mm position during  $[150^\circ, 180^\circ]$
- fall back to the 0 mm position during  $[180^\circ, 360^\circ]$

Design the displacement of the cam with an objective to minimize the maximum acceleration. You must present the equations of displacement, velocity, and acceleration and jerk of your cam for both rise and fall, and sketch the rise profile for  $s$ ,  $v$ ,  $a$ , and  $j$ , and compute the maximum acceleration and jerk for the rise.

Select a base circle and sketch the cam profile for a flat-faced follower. Compute the pressure angles at the following cam positions:  $75^\circ$  and  $270^\circ$ . Sketch the cam profile and specify any iterations needed from the computed two pressure angles. Do not carry out any iterations.

3. A planetary gear train is shown below. Gears 2 and 3 are mounted on the same shaft. All tooth numbers are indicated in the diagram. When gear 1 rotates at 300 rpm (ccw when viewed from the left), determine

- (i) the angular speed and sense of rotation of the arm (output), and
- (ii) the angular velocity of gear 3 relative to the input shaft.

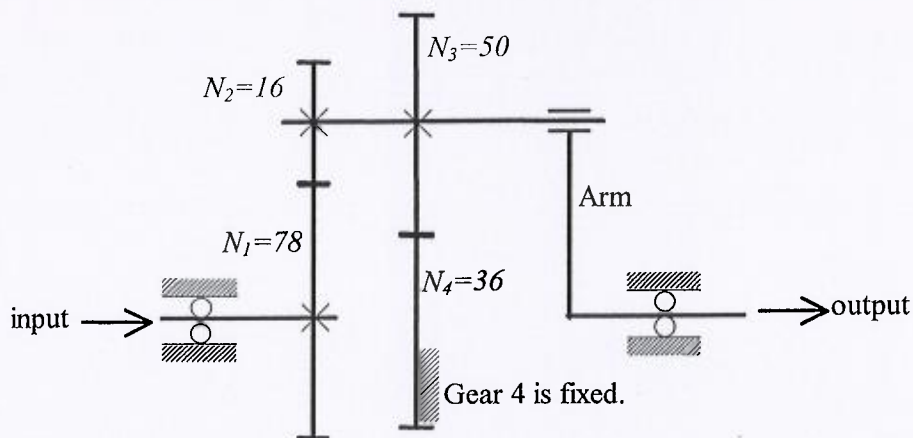

4. A four-bar mechanism is shown below. The input link rotates at an angular velocity of 1800 rpm (CCW). The masses of the crank and the follower are negligible. The coupler is considered as a uniform rod (0.2 kg in mass). Design an effective balancing scheme to reduce the maximum shaking force by 50%.

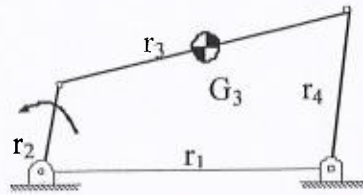

- $r_1 = 145 \text{ mm}$
- $r_2 = 45 \text{ mm}$
- $r_3 = 150 \text{ mm}$
- $r_4 = 80 \text{ mm}$

Not to scale

5. A coupled vibration system is shown below. For  $m = 10 \text{ kg}$  and  $k = 50\,000 \text{ N/m}$ , determine
- equations of motion of the two masses in the vertical direction in matrix form,
  - natural frequencies of free vibration,
  - amplitude ratios associated with the two natural frequencies,
  - modal vectors,
  - modal masses,
  - modal vectors normalized with respect to mass matrix, and
  - free vibration when the top mass suddenly obtains an initial velocity of  $10 \text{ m/s}$ .

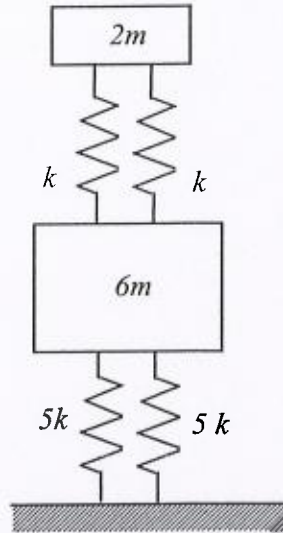

6. A uniform bar ( $m_1 = 10 \text{ kg}$  and  $l = 1 \text{ m}$  length) hinged at its top end is initially at its vertical, equilibrium position. A linear spring ( $k = 1000 \text{ N/m}$ ) is attached to the pendulum as shown below. Damping coefficient  $c$  is  $50 \text{ Ns/m}$ . A small block of mass  $m_2 = 1 \text{ kg}$  travels at a constant velocity of  $2.5 \text{ m/s}$  toward the pendulum. Assume that the impact is perfectly plastic. Determine:
- the equation of motion of the system
  - the natural frequency in  $\text{rad/s}$ , and
  - the ensuing motion after impact.

