

**National Examinations – December 2013**

**07-Mec-A4, Design and Manufacture of Machine Elements**

**3 Hours Duration**

**Notes:**

1. If doubt exists as to the interpretation of any question, the candidate is urged to submit with the answer paper, a clear statement of any assumptions made.
2. This is an open book examination. Candidates may use any non-communicating calculator.
3. There are 8 questions on the following 6 pages, divided into Part A and Part B. Answer three (3) questions from Part A and two (2) questions from Part B. 5 (five) questions constitute a complete paper. Only the first five questions, as they appear in your answer book, will be marked. Clearly cross off any question you do not want marked.
4. All questions are of equal mark value (20%).

**PART A: Choose any three (3) problems from part A.**

**Q1**



A large, flat machine-tool base is to be cast with intersecting stiffening ribs on both sides of the flat.

A) Show in a sketch the problem that may arise and suggest (in a separate sketch) at least one design modification to minimize the problem.

B) A part resembling a connecting rod is cast in sand. Porosity is found in the shank and cavities in the heads. Show; with appropriate design sketches, (I) a remedy for the heads and (II) two possible remedies for the shank. Explain each remedy in one sentence.

**Q2**

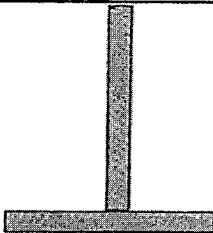
Redesign the three joints shown so that they are suitable for adhesive bonding.

	Redesign for Adhesive Bonding
	
	
	

**Q3**

- a) Figure *a* shows the use of heating bands around the joints to be welded. Why are these bands Used?
- b) The crack shown in the figure *b* developed during the welding process. The parts are made of low carbon steel. What is the most likely cause of this defect?
- c) Suggest ways of preventing this defect from happening again.

HEATING  
BANDS

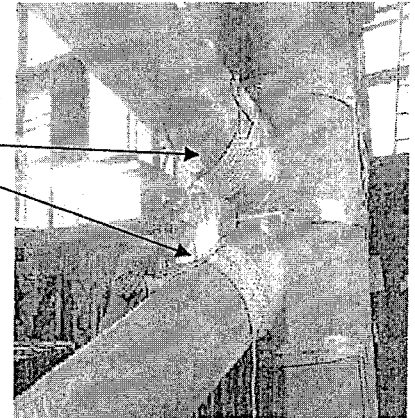

Figure *a*

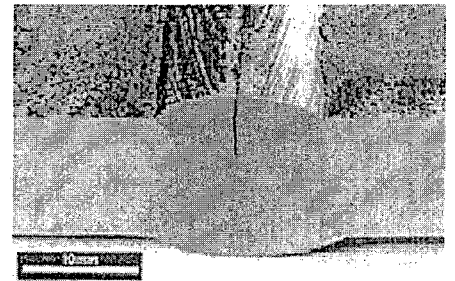

Figure *b*

**Q4**

- A hard steel plate is blanked on a mechanical press. In each cut, the press suddenly "snaps," with a loud bang.
- (a) Find an explanation for the phenomenon. (use appropriate sketches)
- (b) Suggest a way of minimizing it (the material cannot be changed).

PART B: Choose any two(2) problems from part B.

Q5 Find the value of the force on the most heavily loaded rivet in Fig. A

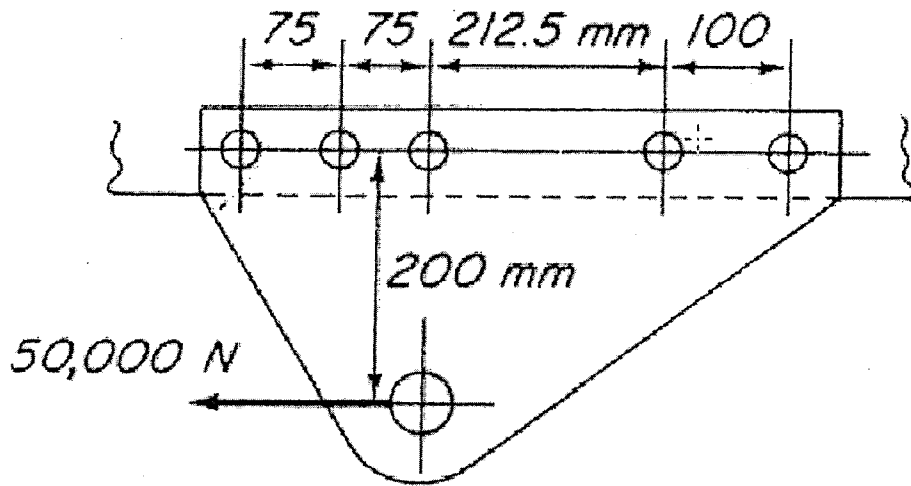

FIGURE A

Q6

Make a drawing for the element at  $A$  of the beam in Fig. B with horizontal and vertical sides, and show the stresses acting on it. Construct the corresponding Mohr circle. Draw the element for the principal stresses correctly oriented and show the stresses acting on it. Do the same for the element of maximum shear stress.

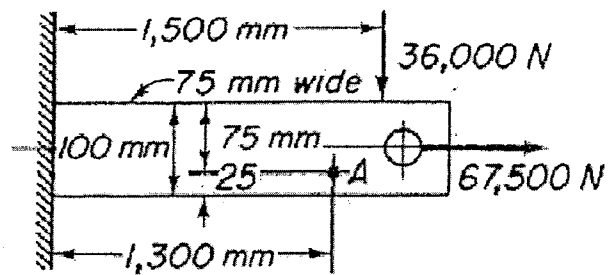

FIGURE B

Q7

In Fig. C the three bearings are at the same elevation.

- (a) When all bearings are on solid supports find the value of  $R_2$ .
- (b) When the center bearing is 0.040 in. lower than the other two find the value of  $R_2$ .
- (c) Suppose the center bearing is resting on an elastic support that could be represented by a spring of constant equal to 30,000 lb/in. Find  $R_2$ .

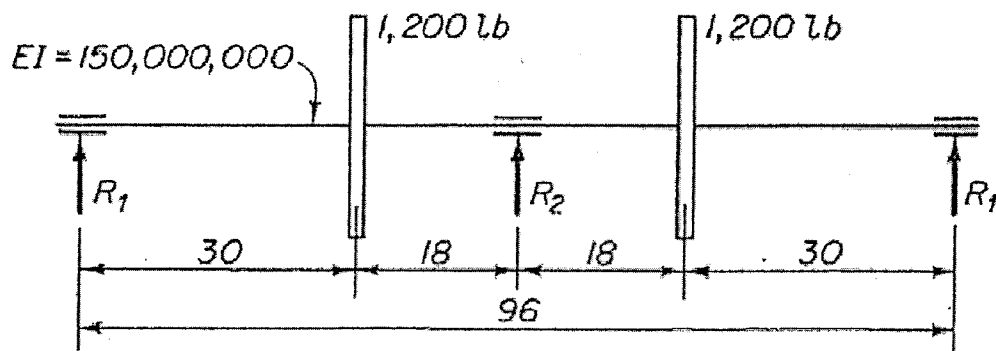

FIGURE C

• Q8

Assume the brake in Fig. D has short shoes. The coefficient of friction is 0.3. Find the value of distance  $a$  that will cause the wear to be the same for both shoes.

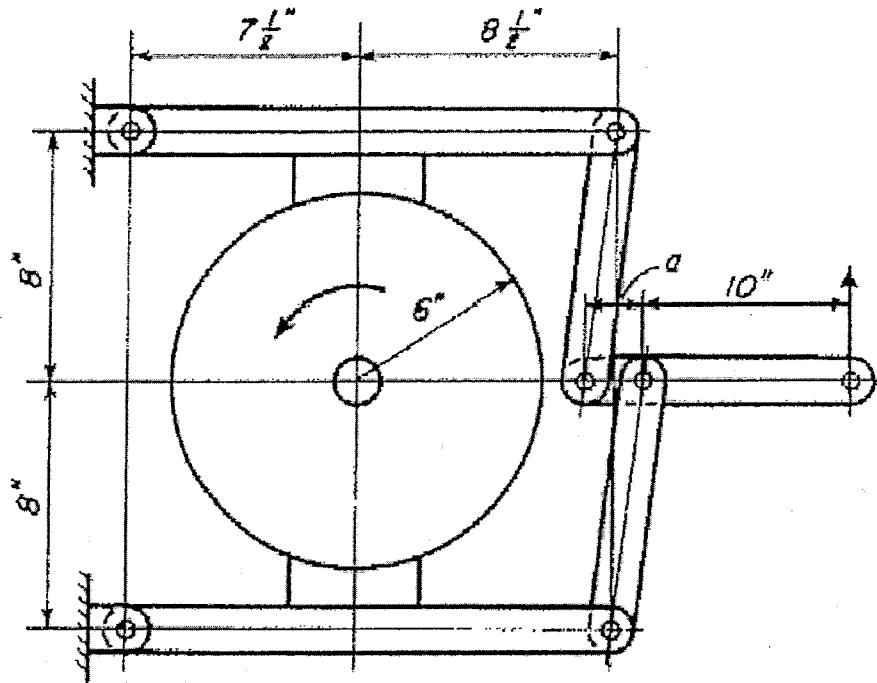

FIGURE D