

National Examinations – May 2017

16-Civ-A2, Elementary Structural Design

3 Hour Duration

NOTES

1. If doubt exists as to the interpretation of any question, the candidate is urged to submit with the answer paper a clear statement of any assumptions made.
2. This is a **"CLOSED BOOK"** examination. Handbooks and textbooks are permitted. **No notes or sheets are allowed.** Candidates may use one of two calculators, the Casio or Sharp approved models. You must indicate the type of calculator being used, i.e. write the name and model designation of your calculator on the first inside left-hand sheet of the exam work book.
3. Solutions must be to the following standards:

Steel:	CSA-S16 (latest edition)
Concrete:	CSA-A23.3 (latest edition)
Timber:	CSA-O86 (latest edition)
4. A total of **five** solutions is required. Only the first five as they appear in your answer book will be marked.

Do two questions from Part A.
Do two questions from Part B.
Do the one question in Part C.
5. All questions are of equal value.
6. **All loads shown are unfactored.**

Marking Scheme:

- A1. (12 + 8)
- A2. (8 + 12)
- A3. (8 + 12)
- B1. (12 + 8)
- B2. (10 + 8 + 2)
- B3. (12 + 8)
- C1. (8 + 6 + 6)

Part A (Do two of three questions)

- A1. Figure A1 shows a loaded cantilevered beam AB, W530 x 92 of G40.21 350W. It is to be welded to the flange of a steel column, W610 x 241, of G40.21 350 W. Design a welded connection at A to transfer the required factored moment and shear.
- A2. Figure A2 shows a cross-section of a steel beam built-up from 25 mm G40.21-350W steel plates. Calculate the moments of resistance of the cross-section about the centroidal axes, x-x and y-y.
- A3. The steel cross-section of Question A2 is used as a column, fixed at its top and bottom. The column is 9 m high and it is subjected to a vertical load P_f , applied at O along the axis y-y, 60 mm from the centroid C. Calculate the maximum factored load, P_f that the column can carry.

Part B (Do two of three questions)

- B1. Figure B1 shows the profile of a determinate reinforced concrete frame, ABC. Design a rectangular cross-section and the reinforcing for flexure and shear of the column BC. Show the layout of the reinforcement. (Use $f'_c = 35$ MPa and $f_y = 400$ MPa).
- B2. A reinforced concrete beam with an overhang, is loaded as shown in Figure B2. Determine the dimensions of its rectangular cross-section and the steel reinforcements to satisfy moment and shear. Take into account the self-weight of the beam (Use $f'_c = 35$ MPa and $f_y = 400$ MPa).
- B3. Figure B3 shows the cross-section of a reinforced concrete culvert. For the given dimensions and steel reinforcing, calculate its moment (M_r) and shear (V_r) resistances. (Use $f'_c = 35$ MPa and $f_y = 400$ MPa.)

Part C (Do question C1)

- C1. Specification for a timber roof requires the use of single span oblique sawn timber purlins. Using treated D. Fir-L select structural grade, in dry service conditions, design the purlins to satisfy the following conditions:
- Purlin spacing = 2.5 m
 - Purlin span = 5 m
 - Roof pitch = 18.0°
 - Specified dead load (including weight of purlin) = 1.5 kPa
 - Specified live load = 3.0 kPa. Assume standard duration of load.

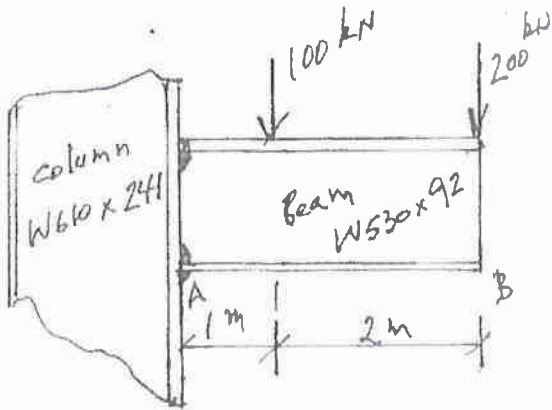

FIG. A1

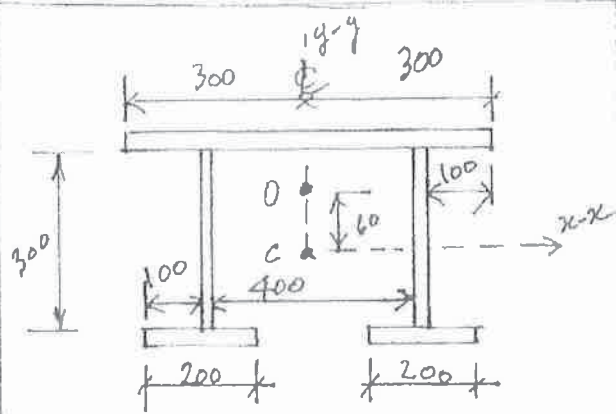

FIG. A2

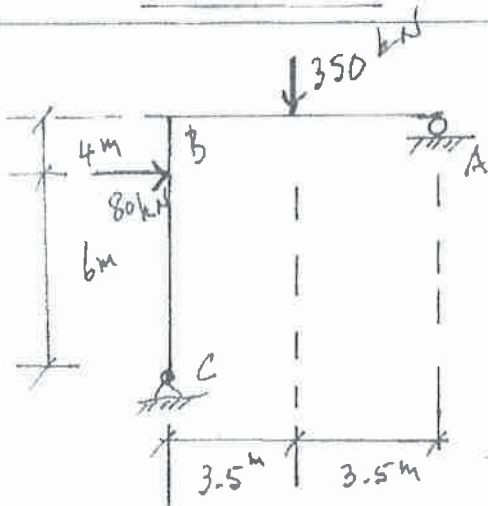

FIG. B1

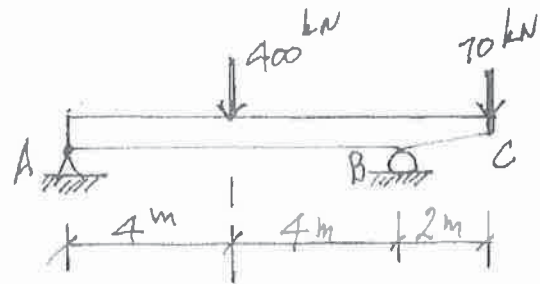

FIG. B2

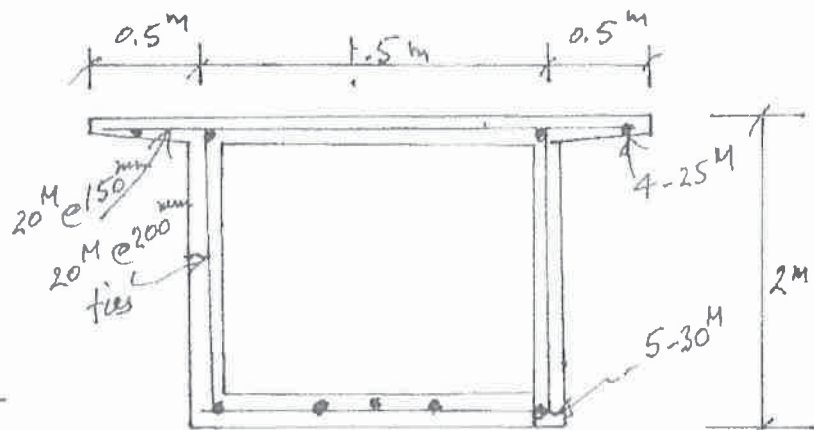

FIG. B3