

NATIONAL EXAMS DECEMBER 2013

98-CIV-A1 ELEMENTARY

STRUCTURAL ANALYSIS

3 HOURS DURATION

NOTES:

1. If doubt exists as to the interpretation of any question, the candidate is urged to submit with the answer paper a clear statement of any assumption made.
2. Each candidate may use an approved model of Sharp or Casio calculator; otherwise, this is a CLOSED BOOK Examination.
3. Six questions constitute a complete paper. Answer ALL questions #1 through #5; answer ONLY ONE of #6, #7 or #8.
4. The marks assigned to each question are shown in the left margin.

FRONT PAGE

- (6) 1. For each of the structures shown state whether it is unstable, statically determinate, or statically indeterminate. If the structure is statically indeterminate, state the degree of indeterminacy. Structures a) through d) have beam-type members.

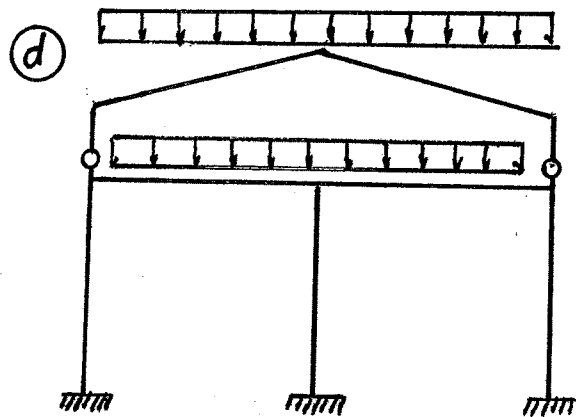
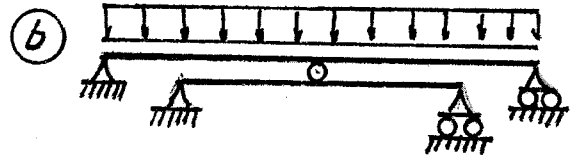
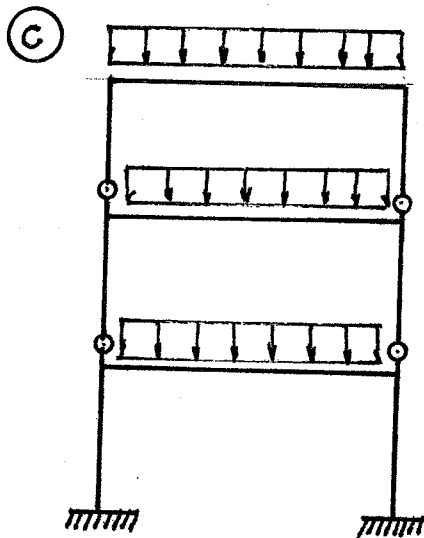
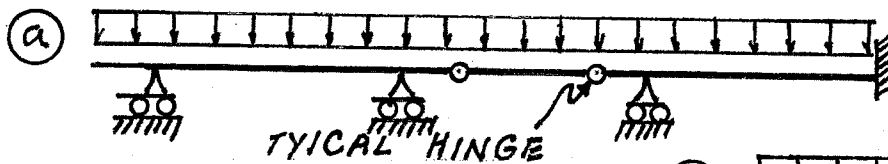

Structures e) through f) have truss-type members. Diagonals are not connected where they cross.

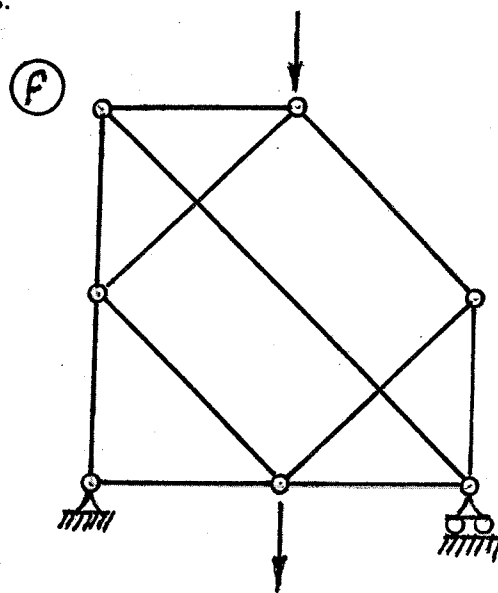
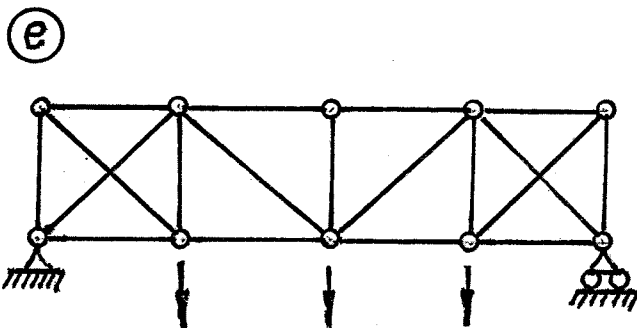

- (18) 2. For each structure shown, compute the reactions and draw shear and bending moment diagrams. Indicate which are positive and which are negative segments of each bending moment diagram. For each shear and bending moment diagram, calculate and indicate the magnitudes of the maximum positive and maximum negative ordinates.

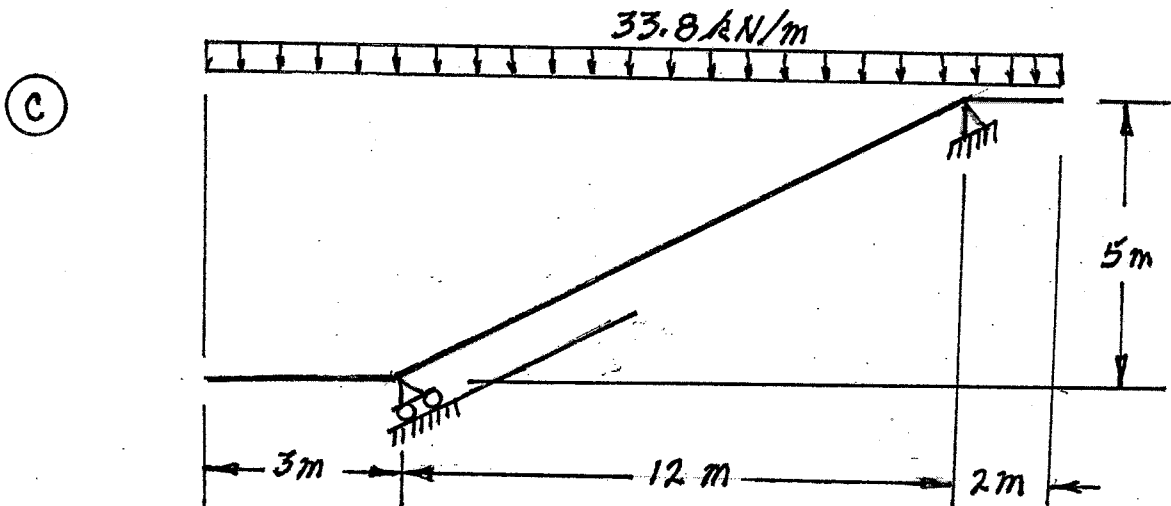
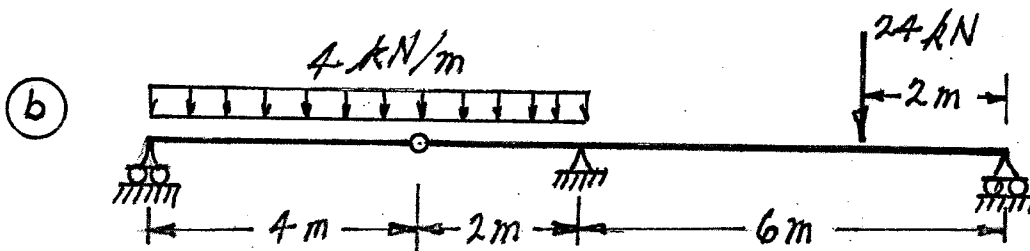
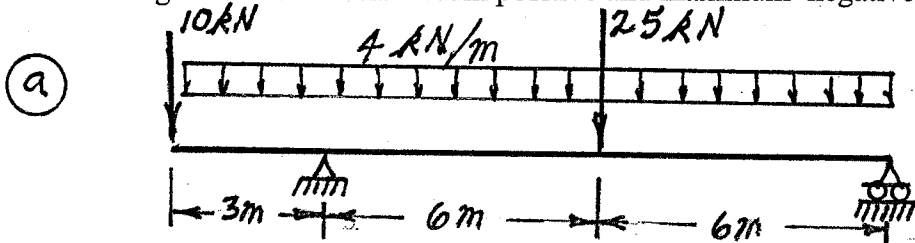

- (18) 3. Calculate the vertical deflection at point (B) on the non-prismatic beam shown below. $EI = 8.0 \times 10^3 \text{ kN.m}^2$.

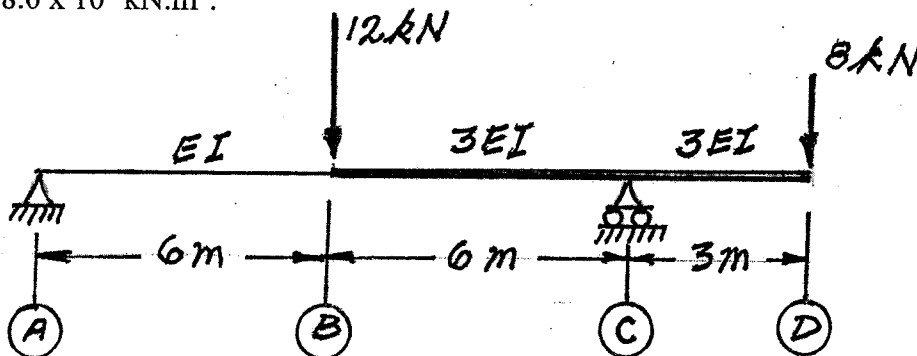

(18) 4. For the trusses shown below, calculate the forces in the members that are listed. For each force, indicate whether it is tension or compression.

a) Calculate the forces in:

- $L_1 - U_1$
- $U_1 - L_2$ and
- $U_1 - L_3$

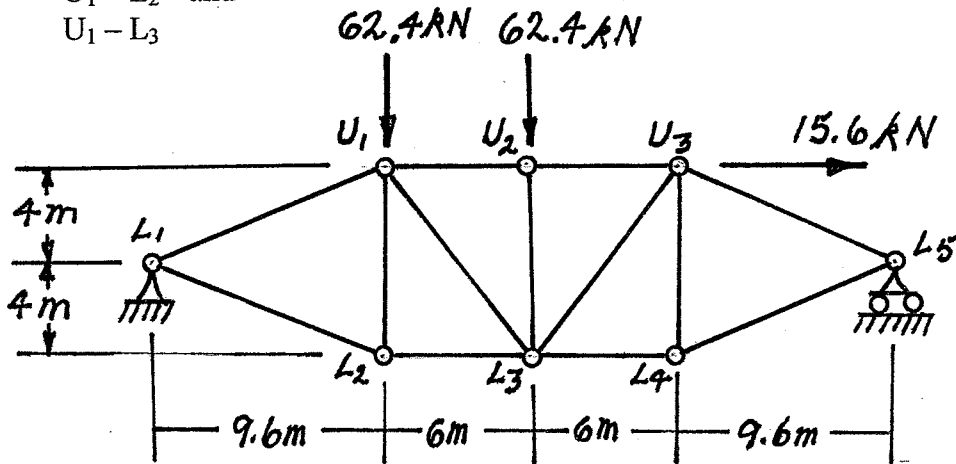

b) Calculate the forces in:

- $L_2 - L_3$
- $M_1 - L_3$ and
- $M_1 - M_2$

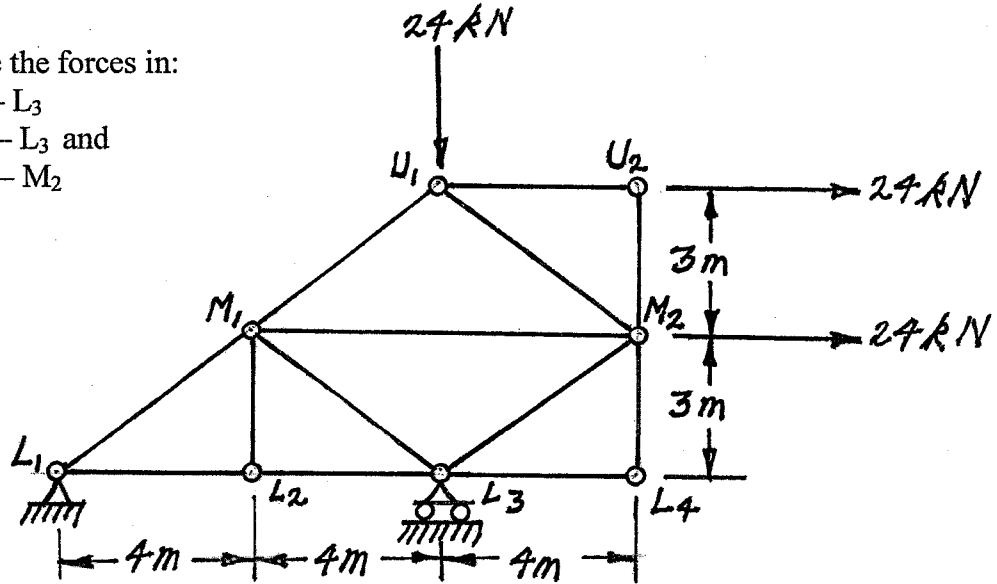

- (20) 5. For the frame shown below, using the moment-distribution method or the slope-deflection method, calculate and plot the shear force and bending moment diagrams. On both diagrams for each member, calculate and label the maximum and minimum ordinates (Minimum ordinates are frequently negative values). All members have the same EI values and are inextensible.

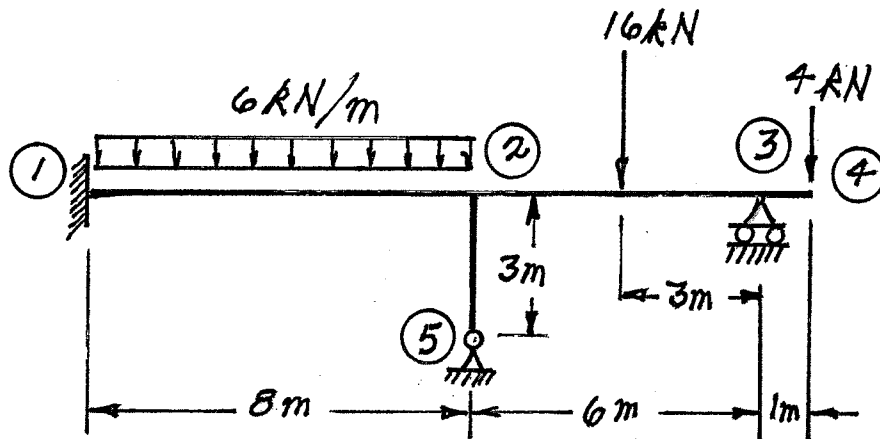

Select and answer ONE QUESTION ONLY from Questions #6, #7 or #8.

- (20) 6. Use the principle of virtual work to calculate the vertical deflection at joint L_2 on the truss shown below. All members have the same EA value that is $4.0 \times 10^4 \text{ kN}$.

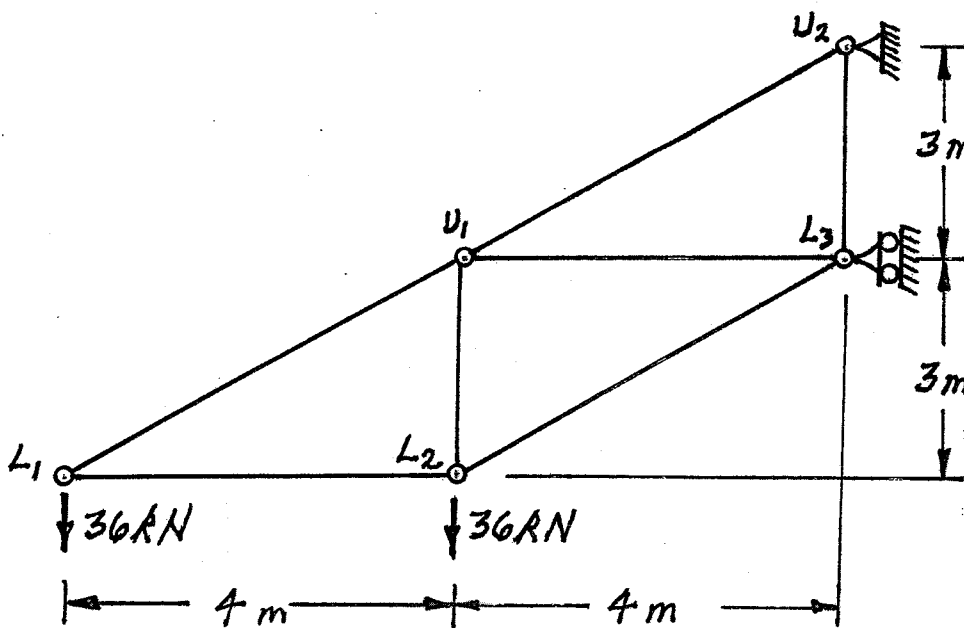

Select and answer ONE QUESTION ONLY from Questions #6, #7 or #8.

- (20) 7. a) Loads move along the bottom chord level of the truss shown. Draw influence lines for forces in the members listed beside the truss. For each influence line, calculate and indicate the value of the influence coefficient that has the maximum absolute value.

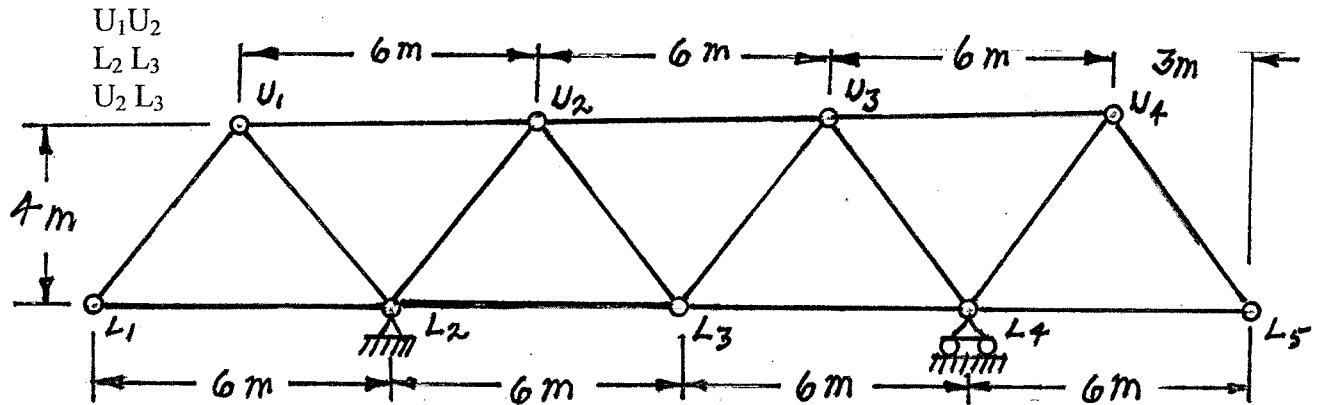

- b) A vehicle, which is idealized as a uniformly distributed load over a length of 4 m, moves across the frame structure shown below. Calculate and show the influence line for bending moment immediately left of joint (C). Also calculate the largest negative bending moment left of joint (C) occurring while the idealized vehicle crosses the structure.

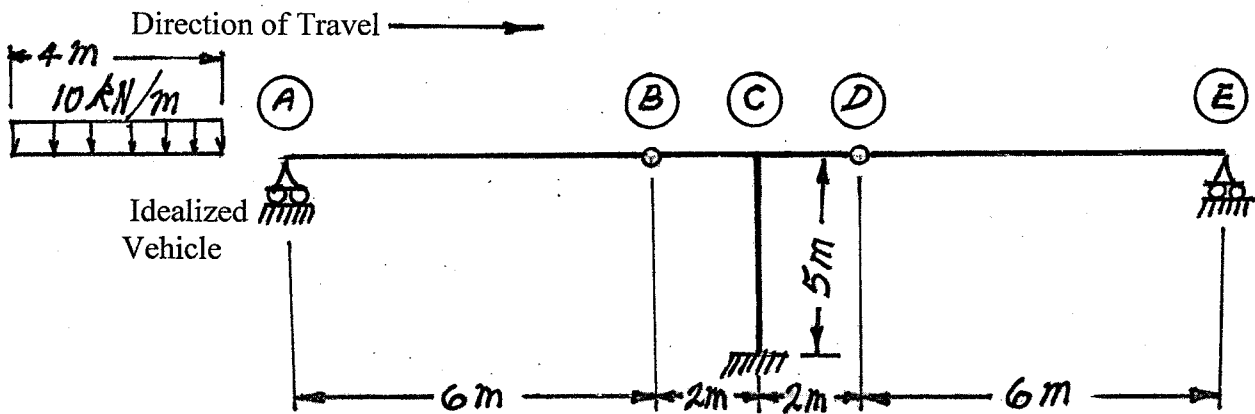

Select and answer ONE QUESTION ONLY from Questions #6, #7 or #8.

- (20) 8. For the structure shown below, compute the reactions and draw shear and bending moment diagrams. On both diagrams for each member, calculate and label the maximum and minimum ordinates (Minimum ordinates are frequently negative values).

