

NATIONAL EXAMS – December 2013

98-Civ-B2, Advanced Structural Design

3 Hours Duration

NOTES:

1. If doubt exists as to the interpretation of any question, the candidate is urged to submit with the answer paper, a clear statement of any assumptions made.
2. This is a “**CLOSED BOOK**” examination. However, handbooks and textbooks are permitted. **NO notes or sheets are allowed.** Candidates may use one of two calculators, the Casio or Sharp approved models. You must indicate the type of calculator being used, i.e. write the name and model designation of your calculator on the first inside left-hand sheet of the exam workbook.
3. Any five questions constitute a complete paper. Only the first five questions as they appear in your answer will be marked.
4. All questions are of equal value.
5. **All loads shown are unfactored.**

USE THE FOLLOWING DESIGN DATA

Design in SI

Concrete $f_c = 30$ MPa
Structural Steel $f_y = 350$ MPa
Rebar $f_y = 400$ MPa

Prestressed f_c (at transfer) = 35 MPa
Concrete $f_c = 50$ MPa
 $n = 6$
 $f_{ult.} = 1750$ MPa
 $f_y = 1450$ MPa
 $f_{initial} = 1200$ MPa
 Losses in prestress = 240 MPa

Marks For

Question 1: (12 + 6 + 2)
Question 2: (14 + 6)
Question 3: (14 + 6)
Question 4: (12 + 6 + 2)
Question 5: (12 + 8)
Question 6: (14 + 6)
Question 7: (15 + 5)

1. The continuous welded steel-plate girder, Figure 1 is simply supported at A and rigidly supported by a very stiff column at C. Choose a suitable cross-section to satisfy:
 - (a) Flexure;
 - (b) Shear; and
 - (c) their interaction.

[Assume adequate size for the load base plates.]

2. The rigid frame in Figure 2 is to be designed in reinforced concrete. Using the Limit States Design method:
 - (a) Determine the amount and layout of reinforced steel required to satisfy flexure and shear for member BC, using a rectangular cross-section.
 - (b) Check the serviceability requirement for the mid-span deflection of member BC.

[Assume lateral support at all joints and load points.]

3. Using the Limit States Design method, design a rectangular cross-section for the reinforced concrete column AB in Figure 2, carrying out the required strength and stability checks. Also estimate the size of the concrete footing at A, assuming a value for the soil bearing capacity.

4. Figure 3 shows a prestressed concrete T-beam.

- (a) Design the beam, allowing no tension in the cross-section.
- (b) Show the profile of the prestressing steel.

[Use the gross section in calculating the moment of inertia.]

5. The rigid frame in Figure 2 is to be designed in steel using the Plastic Method of Design. All members have the same plastic moment capacity.

- (a) Select a section for the members.
- (b) Design the welded corner at B.

[Assume lateral support at load locations and joints A and D. Neglect the effect of axial and shear deformations.]

6. Design a steel section for the beam-column AB in Figure 2 (Question 5) satisfying the required strength and stability conditions.

[Assume lateral support at all load and joint locations.]

7. The cross-section of a composite steel-reinforced concrete slab floor system is shown in Figure 4. It is to be designed as simply-supported, spanning one-way, and to support heavy loads. The design span length and live load are shown in Figure 4. Assuming complete interaction between the steel beams and the concrete:
- (a) Design the composite cross-section, assuming uniform load distribution.
 - (b) Calculate the required number of shear stud connectors between the steel beams and the concrete slab.

[Assume the steel beams have adequate lateral bracings.]

NOTE: Lateral Support Provided @ 2 m Intervals

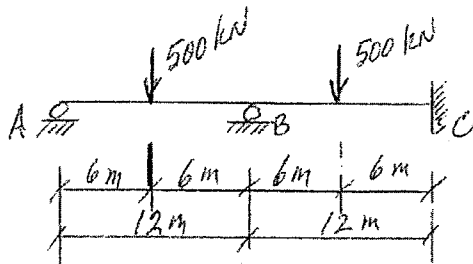

FIGURE 1

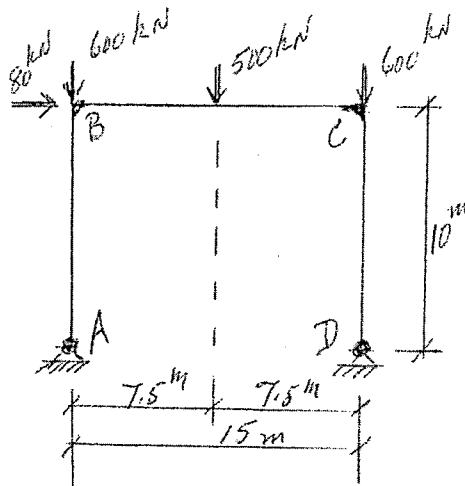

FIGURE 2

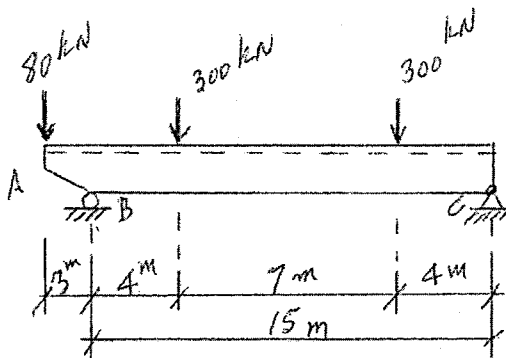

FIGURE 3

NOTE: Design Span length = 15 m; Design Live load = 14 kPa

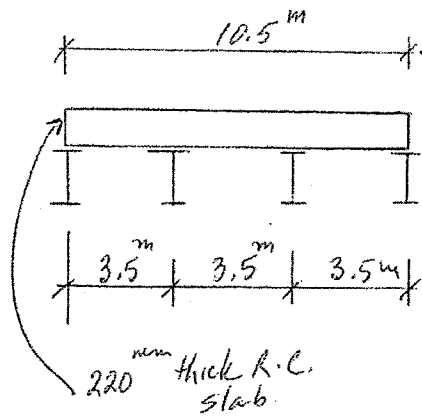

FIGURE 4