

May 2016 National Examinations

98-Nav-A4, Ship Structure and Strength of Ships

3 hours duration

Notes

1) The exam is closed book. No notes or written material of any form is permitted. Casio or Sharp calculator models are allowed. Simple drawing equipment, such as a ruler or straightedge, pencil or pen, eraser are permitted. Some formulae are provided at the end of the exam.

All six questions must be answered totally 100 marks.

2) Even in the case of numerical problems, written explanations of the solution are necessary, and should be neat, legible, clear and concise. Sketches, neatly labeled, should be used as appropriate to illustrate the method of solution. If there is any uncertainty, the candidate should explain the assumptions used in preparing the answer. The clarity of the answer will influence the grade.

Q1. General Aspects of Ship Structures

1a) [10] For each of the following structural issues or concepts in a ship structures, provide a description of the issue or item (and sketch if needed)

- i: long plate theory
- ii: sandwich panel
- iii: warpage in open sections
- v: main deck shear lag
- vi: elastic-perfectly plastic

1b) [10] Define the following terms:

- i: hot spot stress
- ii: hogging
- iii: nil ductility temperature
- iv: lateral torsional buckling
- v: section modulus

Q2. Hydrostatic Loads

2 a) [10] For each of the three hull cross-sections shown below, sketch a bonjean curve, with dimensions.

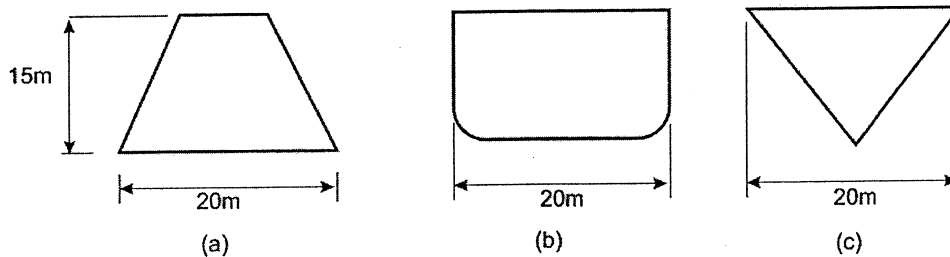

2 b) [10] There is a vessel 100m in length which weighs 10,000 tonnes. For a condition of the vessel at rest in still water, the total vessel weight and corresponding buoyancy for each of ten stations is given in the table below. Each station represents 10m of the vessel. Compute and plot the shear force and bending moment diagrams.

station	1	2	3	4	5	6	7	8	9	10
Weight [t]	450	1100	1200	1200	1000	1000	1000	1100	1100	850
Buoyancy [t]	500	700	1000	1250	1350	1350	1300	1100	850	600

Q3. Structural Mechanics

3 a) [10] The figure below shows a cross section of a single transverse L frame attached to shell plate. For this section:

- locate the horizontal neutral
- find the moment of inertia
- find the elastic section modulus
- find the plastic section modulus

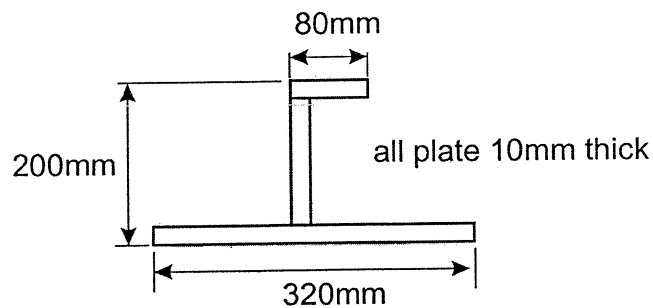

3 b) [10] Beam Bending. For the beam sketch below:

- compute and plot the shear force and bending moment diagrams (with numerical values). Also sketch (without numbers) the slope and deflection diagrams.
- assuming that $EI=1.0 \text{ kN}\cdot\text{m}^2$ for the section, find the vertical deflection at the pin of the beam (you can make use of the tables at the end of the exam).

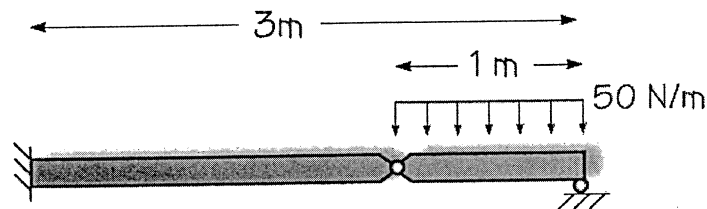

Q4. Material Behaviour and Fatigue

4 a) [8] Explain the following;

- Young's Modulus and Post Yield Modulus
- 3D state of stress
- Engineering stress vs true stress in a uniaxial tension test
- single fillet weld

4 b) [6] Describe the following terms related to Fatigue.

- stress intensity
- Paris Law
- stress range

5. Risk and Reliability

- a) [10] The mean of the load Q is 120 kN. The standard deviation of Q is 40kN. The design will be set such that $R_{5\%} = \gamma_T Q_{10\%}$, where that $R_{5\%}$ and $Q_{10\%}$ are characteristic values and γ_T is a total factor of safety. The standard deviation of R is 20kN. The total factor of safety is 1.20. With the above information, and assuming R & Q are Normal, answer the following questions; (refer to Normal Table at the end)

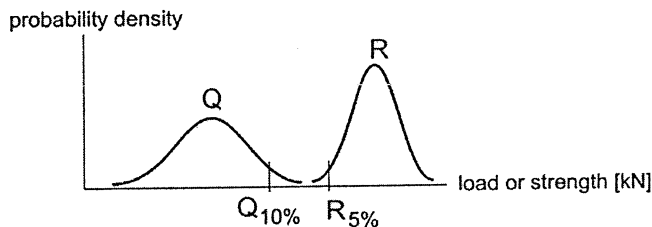

- i) What are the values for $R_{5\%}$ and $Q_{10\%}$?
 - ii) What is the mean value of R ?
 - iii) What are the mean and standard deviation of the Margin?
 - iv) What is the probability of failure?
- b) [6] Discuss the issue of “partial factors of safety” and LRFD.

6. **Shear in Ships** [10]

There is a 15 x 20 channel section subject to a vertical shear force at this section of 100 kN.

- a) Compute the shear flow in the section (plot and give values)
- b) What is the shear stress at the location B?

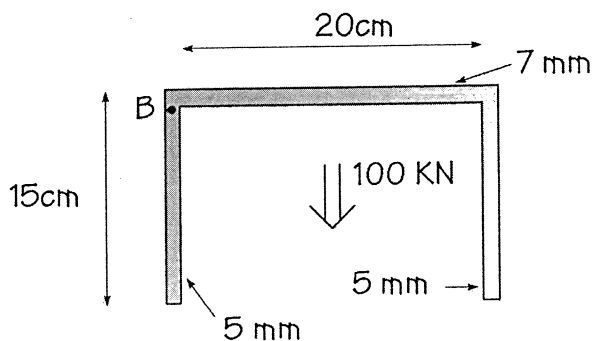

Some Useful Formulae

Weight of a Vessel:

$$W = \Delta = C_B \cdot L \cdot B \cdot T \cdot \gamma$$

2D Hooke's Law

$$\begin{bmatrix} \sigma_x \\ \sigma_y \\ \tau_{xy} \end{bmatrix} = \frac{E}{1-\nu^2} \begin{bmatrix} 1 & \nu & 0 \\ \nu & 1 & 0 \\ 0 & 0 & \frac{1-\nu}{2} \end{bmatrix} \begin{bmatrix} \varepsilon_x \\ \varepsilon_y \\ \gamma_{xy} \end{bmatrix}$$

von Mises

$$\text{yield envelope: } \sigma_1^2 - \sigma_1\sigma_2 + \sigma_2^2 = \sigma_{yield}^2$$

$$\text{equivalent stress: } \sigma_{eqv} = \sqrt{\sigma_1^2 - \sigma_1\sigma_2 + \sigma_2^2}$$

Section Modulus for a rectangle

$$I_{na} = 1/12 a d^3$$

Family of Differential Equations Beam Bending

v = deflection [m]

$v' = \theta$ = slope [rad]

$v''EI = M$ = bending moment [N-m]

$v'''EI = Q$ = shear force [N]

$v''''EI = P$ = line load [N/m]

Shear flow: $q = \tau t$, $q = Q m / I$
 $m = \int y t ds$

Torque: $M_x = 2qA$

Normal Distribution (Cumulative)

Pr(X<x)										
x	0	1	2	3	4	5	6	7	8	9
0	0.5	0.503989	0.507978	0.511967	0.515953	0.519939	0.523922	0.527903	0.531881	0.535856
0.1	0.539828	0.543795	0.547758	0.551717	0.55567	0.559618	0.563559	0.567495	0.571424	0.575345
0.2	0.57926	0.583166	0.587064	0.590954	0.594835	0.598706	0.602568	0.60642	0.610261	0.614092
0.3	0.617911	0.621719	0.625516	0.6293	0.633072	0.636831	0.640576	0.644309	0.648027	0.651732
0.4	0.655422	0.659097	0.662757	0.666402	0.670031	0.673645	0.677242	0.680822	0.684386	0.687933
0.5	0.691462	0.694974	0.698468	0.701944	0.705402	0.70884	0.71226	0.715661	0.719043	0.722405
0.6	0.725747	0.729069	0.732371	0.735653	0.738914	0.742154	0.745373	0.748571	0.751748	0.754903
0.7	0.758036	0.761148	0.764238	0.767305	0.77035	0.773373	0.776373	0.77935	0.782305	0.785236
0.8	0.788145	0.79103	0.793892	0.796731	0.799546	0.802338	0.805106	0.80785	0.81057	0.813267
0.9	0.81594	0.818589	0.821214	0.823814	0.826391	0.828944	0.831472	0.833977	0.836457	0.838913
1	0.841345	0.843752	0.846136	0.848495	0.85083	0.853141	0.855428	0.85769	0.859929	0.862143
1.1	0.864334	0.8665	0.868643	0.870762	0.872857	0.874928	0.876976	0.878999	0.881	0.882977
1.2	0.88493	0.88686	0.888767	0.890651	0.892512	0.89435	0.896165	0.897958	0.899727	0.901475
1.3	0.903199	0.904902	0.906582	0.908241	0.909877	0.911492	0.913085	0.914656	0.916207	0.917736
1.4	0.919243	0.92073	0.922196	0.923641	0.925066	0.926471	0.927855	0.929219	0.930563	0.931888
1.5	0.933193	0.934478	0.935744	0.936992	0.93822	0.939429	0.94062	0.941792	0.942947	0.944083
1.6	0.945201	0.946301	0.947384	0.948449	0.949497	0.950529	0.951543	0.95254	0.953521	0.954486
1.7	0.955435	0.956367	0.957284	0.958185	0.959071	0.959941	0.960796	0.961636	0.962462	0.963273
1.8	0.96407	0.964852	0.965621	0.966375	0.967116	0.967843	0.968557	0.969258	0.969946	0.970621
1.9	0.971284	0.971933	0.972571	0.973197	0.97381	0.974412	0.975002	0.975581	0.976148	0.976705
2	0.97725	0.977784	0.978308	0.978822	0.979325	0.979818	0.980301	0.980774	0.981237	0.981691
2.1	0.982136	0.982571	0.982997	0.983414	0.983823	0.984222	0.984614	0.984997	0.985371	0.985738
2.2	0.986097	0.986447	0.986791	0.987126	0.987455	0.987776	0.988089	0.988396	0.988696	0.988989
2.3	0.989276	0.989556	0.98983	0.990097	0.990358	0.990613	0.990863	0.991106	0.991344	0.991576
2.4	0.991802	0.992024	0.99224	0.992451	0.992656	0.992857	0.993053	0.993244	0.993431	0.993613
2.5	0.99379	0.993963	0.994132	0.994297	0.994457	0.994614	0.994766	0.994915	0.99506	0.995201
2.6	0.995339	0.995473	0.995603	0.995731	0.995855	0.995975	0.996093	0.996207	0.996319	0.996427
2.7	0.996533	0.996636	0.996736	0.996833	0.996928	0.99702	0.99711	0.997197	0.997282	0.997365
2.8	0.997445	0.997523	0.997599	0.997673	0.997744	0.997814	0.997882	0.997948	0.998012	0.998074

Deflection and Slopes of Beams

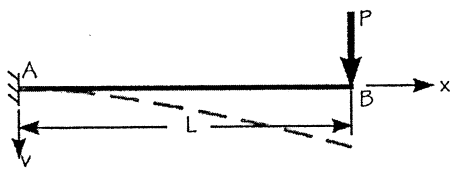
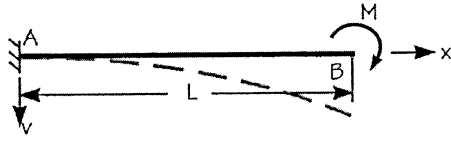
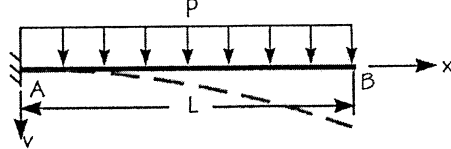
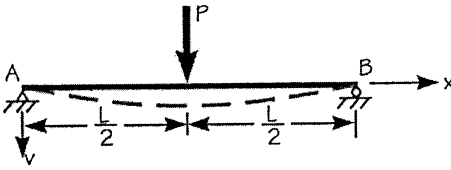
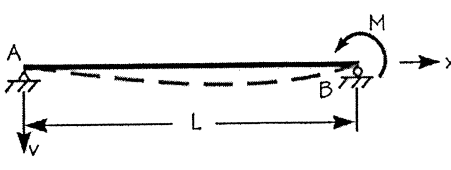
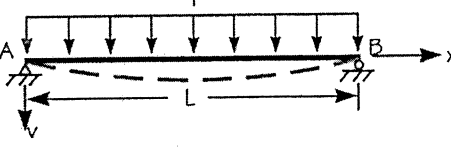
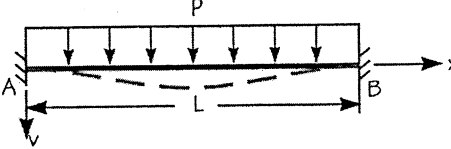
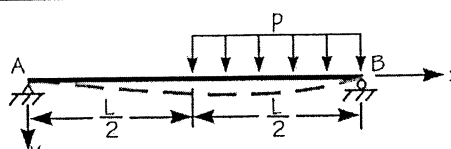
Loading	Deflection	Slope
	$v = \frac{Px^2}{6EI}(3L - x)$ $v_{max} = v_B = \frac{PL^3}{3EI}$	$\theta_B = \frac{PL^2}{2EI}$
	$v = \frac{Mx^2}{2EI}$ $v_{max} = v_B = \frac{ML^2}{2EI}$	$\theta_B = \frac{ML}{EI}$
	$v = \frac{Px^2}{24EI}(6L^2 - 4Lx + x^2)$ $v_{max} = v_B = \frac{PL^4}{8EI}$	$\theta_B = \frac{PL^3}{6EI}$
	$v = \frac{Px^2}{48EI}(3L^2 - 4x^2)$ $v_{max} = \frac{PL^3}{48EI} \text{ @ } x=L/2$	$\theta_A = -\theta_B = \frac{PL^2}{16EI}$
	$v = \frac{Mx}{6EIL}(L^2 - x^2)$ $v_{max} = \frac{ML^2}{9\sqrt{3}EI} \text{ @ } x=L/\sqrt{3}$	$\theta_A = \frac{ML}{6EI}$ $\theta_B = -\frac{ML}{3EI}$
	$v = \frac{Px}{24EI}(L^3 - 2Lx^2 + x^3)$ $v_{max} = \frac{5pL^4}{384EI} \text{ @ } x=L/2$	$\theta_A = -\theta_B = \frac{pL^3}{24EI}$
	$v = \frac{Px^2}{24EI}(L - x)^2$ $v_{max} = \frac{pL^4}{384EI} \text{ @ } x=L/2$	$\theta_A = \theta_B = 0$
	$v_{cont} = \frac{3pL^4}{256EI} \text{ @ } x=L/2$	$\theta_A = \frac{-7pL^3}{384EI}$ $\theta_B = \frac{3pL^3}{128EI}$